

Series DW

2 Port Solenoid Valve

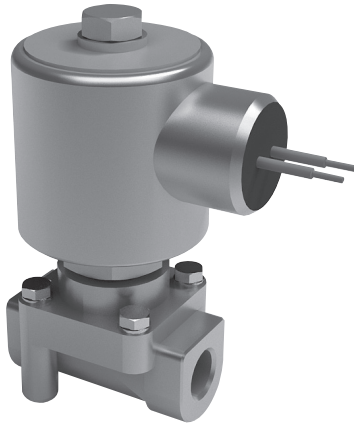

- WIDER RANGE OF OPERATING PRESSURE
 - 0 ~ 7kgf/cm² (TV2W03)
 - 0 ~ 10kgf/cm² (TV2W10,15)
 - 0.3 ~ 10kgf/cm² (TV2W20, 25)
- HIGH FLOW CAPACITY
- LOW VOLTAGE SOLENOID
- CAN BE MOUNTED ANYWHERE

Symbol

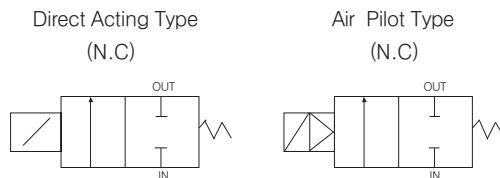

- DW
- DR100
- DR200
- RS1000, 2000
- RS4000
- SI UNIT
- DV1000, DV3000, DV4000
- DS300
- DS3000
- DS5000
- DS2000
- DS6000
- DX1,DX2
- DX1(2)R
- DH
- DP300, DP3000, DP5000
- DM
- DT220

How to Order

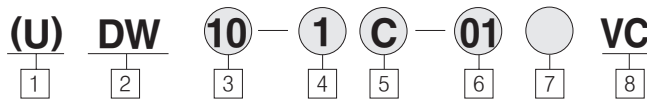

- 1 Series**
Blank : Rc(PT)
U : NPT
- 2 2 Port Solenoid Valve Applicable Fluid**
DW : Water, Air, Oil
DWS : Steam
- 3 Body(Orifice Size)**
03 : φ 2.5—Direct Type Solenoid
10 : φ 10
15 : φ 15
20 : φ 20
25 : φ 25 } Pilot Type Solenoid
- 4 Voltage**
1 : AC110V, 60Hz / AC100V, 50/60Hz
2 : AC220V, 60Hz / AC200V, 50/60Hz
5 : DC24V
9 : Others
- 5 Electrical Entry**
G : Grommet (only Rc(PT) 1/8)
C : Connector
- 6 Port Size Rc(PT)**
01 : 1/8 04 : 1/2
02 : 1/4 06 : 3/4
03 : 3/8 10 : 1
- 7 Material**
Blank : Standard
S : SUS Type
- 8 VC : Vacuum Type(-100kpa)**
(AC Voltage)

Standard Specifications	
Applicable	Air, Water, Oil, Steam
Proof Pressure	1.5MPa(213.35psi)
Fluid Temperature	0~70°C(32°F~158°F)
Ambient and Fluid Temperature	Max. 60°C(140°F)
Electrical Entry	Grommet, Connector
Actuation Type	Direct or Pilot Solenoid
Valve Type	Normal Close
Seat Type	Poppet
Rated Voltage	AC (50/60Hz) 100V, 200V
	DC 24V
Allowance Voltage Range	Rated Voltage ±10%
Coil Insulation	Class B or Equivalent 110°C(230°F)
Power Consumption	AC Inrush 17VA (60Hz)
	AC Holding 15VA (60Hz)
Material	DC 11W
	Body BC 6
	Seal NBR

Series DW

Applicable Specifications

Coil Apparent Power	AC110, 220V(50/60Hz)
	DC 6, 12V
Body Material	Stainless steel(SCS13)
Coil Insulation	H Class(180°C)(356°F)
	AC100, 110, 200, 220V Only

Model

Type	Port (Size)	Pressure		Orifice Size (ϕ mm)	Effective Orifice (mm ²)	Weight (kg)
DW03-*G-0'1	1/8(6A)	0~0.7MPa (0~99.5psi)		2.5	6	0.3
DW03-*G-0'2	1/4(8A)			2.5	6	0.3
DW10-*C-0'2	1/4(8A)	AC: 0~1MPa (0~140.2psi)	DC: 0.03~0.7MPa (4.27~99.5psi)	10	34	0.5
DW10-*C-0'3	3/8(10A)			10	43	0.5
DW15-*C-0'4	1/2(15A)			15	160	0.7
DW20-*C-0'6	3/4(20A)	0.03~1MPa (4.27~140.2psi)		20	170	0.9
DW25-*C-10	1(25A)			25	225	1.2

Series DW

Direct Type

DW ○ 03 - ○ - 01
02

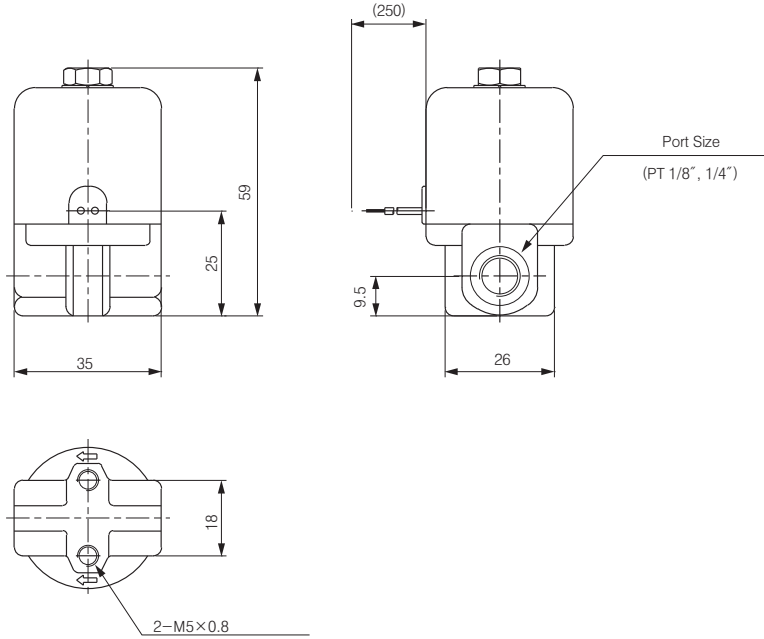

※ () is for DC24V

DW
DR100
DR200
RS1000, 2000
RS4000
SI UNIT
DV1000 DV3000 DV4000
DS300
DS3000
DS5000
DS2000
DS6000
DX1,DX2
DX1(2)R
DH
DP300 DP3000 DP5000
DM
DT220

Pilot Type

DW ○ 10 - ○ - 02
03

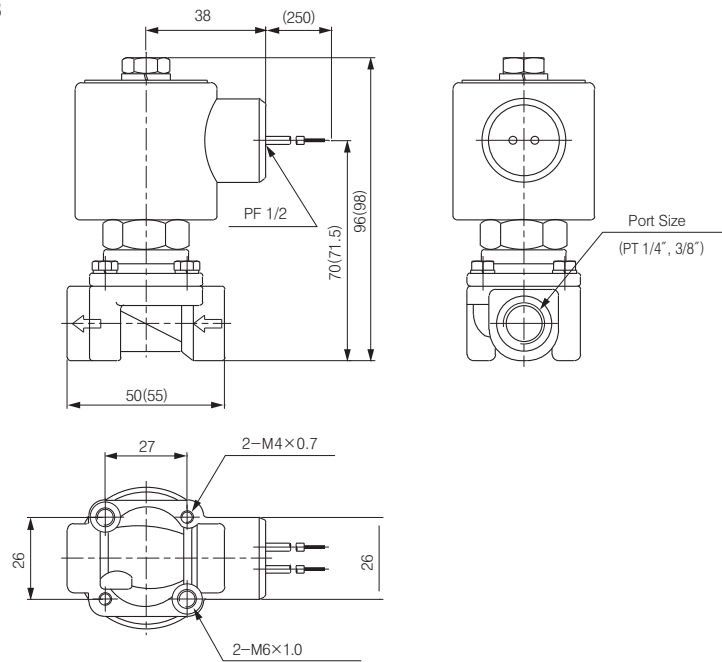

※ () is for DC24V

Series DW

Pilot Type

DW ○ 15 - ○ - 04

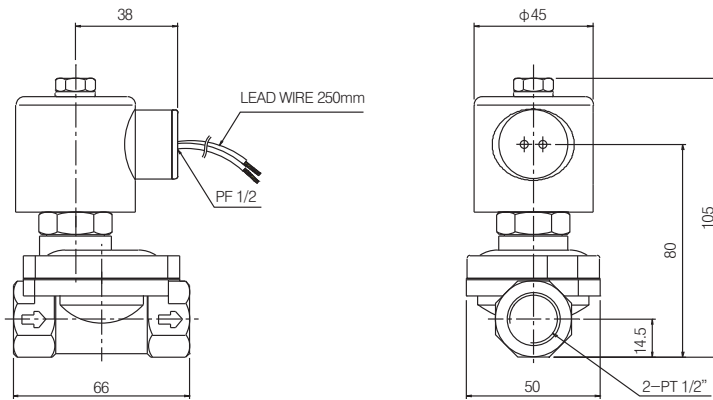

Pilot Type

DW ○ 20 - ○ - 06
DW ○ 25 - ○ - 10

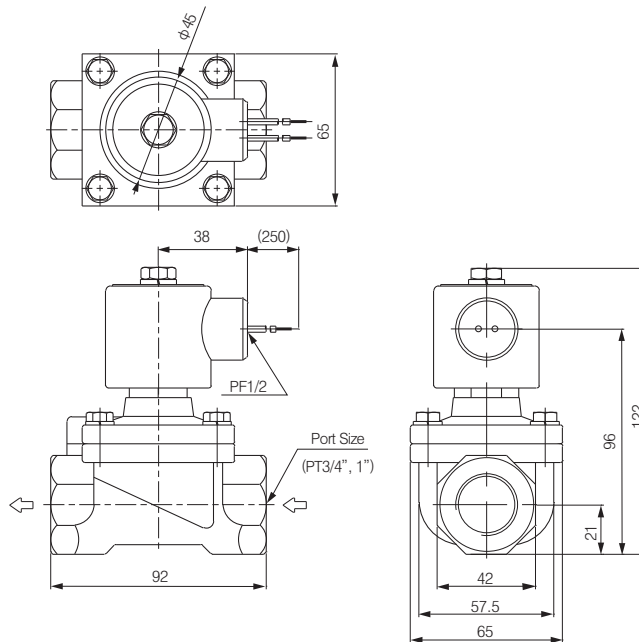

⚠️ Precautions

Piping

- 1 The piping should be thoroughly flushed to remove sludge, cutting oil and dust.
- 2 During piping and coupling connection, care should be taken so as to prevent contamination by cut thread chips or sealing materials. (one screw thread should extend beyond the tape when applying sealing tape to threads)
- 3 Be sure to pay attention to the piping direction (IN, OUT). IN or other marks are indicated on the inlet side.
- 4 It is preferred that the coil should not be subjected to an extended force. Be sure to apply a wrench to the outside of the pipe mounting area only when tightening.
- 5 Grounding the piping system should be avoided. Otherwise electrolytic corrosion may occur.
- 6 It is preferred to install a relief valve within the circuit so as to prevent collection of fluid within the piping circuit.

Mounting

- 1 It is preferred that the solenoid valve can be installed in any orientation. Foreign material in the fluid is liable to adhere to the core when mounted upside down. Avoid installation. Be sure to mount the valve with its coil facing up.
- 2 Coil assemble with insulating material etc should be avoided. The coil may burn out. Anti-freezing tape, heater, etc. Should be applied to piping and body areas only.
- 3 Placing the valve in areas of severe vibration is avoided. Otherwise, the arm to a minimum to avoid resonance may be shortened.

Storage

It is preferred that in order to prevent corrosion and deterioration of rubber parts, long time storage after using the valve for water will require complete removal of moisture.

Long Period Energization or De-energization

The valve switching period is determined based on the type and quality of the fluid. The valve should be switched at least once every 10 days when pure water is taken as a standard. A system check mechanism should be installed if the cycle is greater than 10 days. The valve should not be used as an emergency circuit breaker. Be sure to specify operational conditions for use under conditions similar to that.

Fluid Temperature

Be sure to check the temperature range for each model. The temperature range changes according to the sealing material, coil insulation, power, supply, etc. Contact our representative for use other than standard use.

Wiring

- 1 Be sure to check that the minimum diameter for 0.5mm².
- 2 It is preferred to use an electric circuit which prevents chattering at the point of contact.
- 3 It is preferred to place a surge suppressor in parallel with the solenoid voltage suppressor (option) when the electric is apt to be damaged by surge voltage.
- 4 Be sure to check that the allowable voltage range is -10%~+10% of the rated voltage. In event that great response is desired for DC power, it is needed to adjust the voltage range to within $\pm 5\%$ of the rated voltage. Voltage drop is measured at a part of the lead wire connected to the coil.
- 5 Be sure to check that the voltage found on both ends of the coil is AC:20% or less of the rated voltage DC:2% or less of the rated voltage when it de-energizes.
Here, the DC value is for a temperature of $20\pm 5^{\circ}\text{C}$.
At lower temperatures, the DC value will be lower.

Applicable Fluid

1 Fluid Classification

When selecting a valve for your application, ensure the compatibility of the fluid and valve materials. Generally, the recommended viscosity of fluid is 50cSt max.

For further details, contact our representative.

<Reference> Standard materials

Body: Brass or BC6 Seal: NBR, Coil: Insulation Type B.

These are for water, air, and oil use. For materials other than standard, refer to the "Option list" and "Applicable fluid check list." The specifications may be slightly different.

2 Fluid Quality

Wearing of the valve seat and iron core may be promoted by fluid mixed with foreign material. Function of the valve or sealing trouble may be on adhesion of foreign particles to the iron core and sliding section. So as to prevent this, it is preferred to place a filter (strainer) immediately in front of the solenoid valve. In general, a mesh of 80~100 is recommended.

3 Lubricant

Lubricant is not needed in our solenoid valves. However, be sure to check that lubricated air will increase their life.

4 When flammable oil and gas is supposed to be used, prevention of leakage both inside and outside of the valve should be exercised.

5 When oil and other impurities are not allowed in the fluid, be sure to use nonlube treated parts.

6 The option and fluid may not be applicable as they are since only general applications are shown. It is needed to check actual conditions on your own for appropriate selection under conditions near the limit of valve operation.

DW

DR100

DR200

RS1000,
2000

RS4000

SI UNIT

DV1000
DV3000
DV4000

DS300

DS3000

DS5000

DS2000

DS6000

DX1,DX2

DX1(2)R

DH

DP300
DP3000
DP5000

DM

DT220