

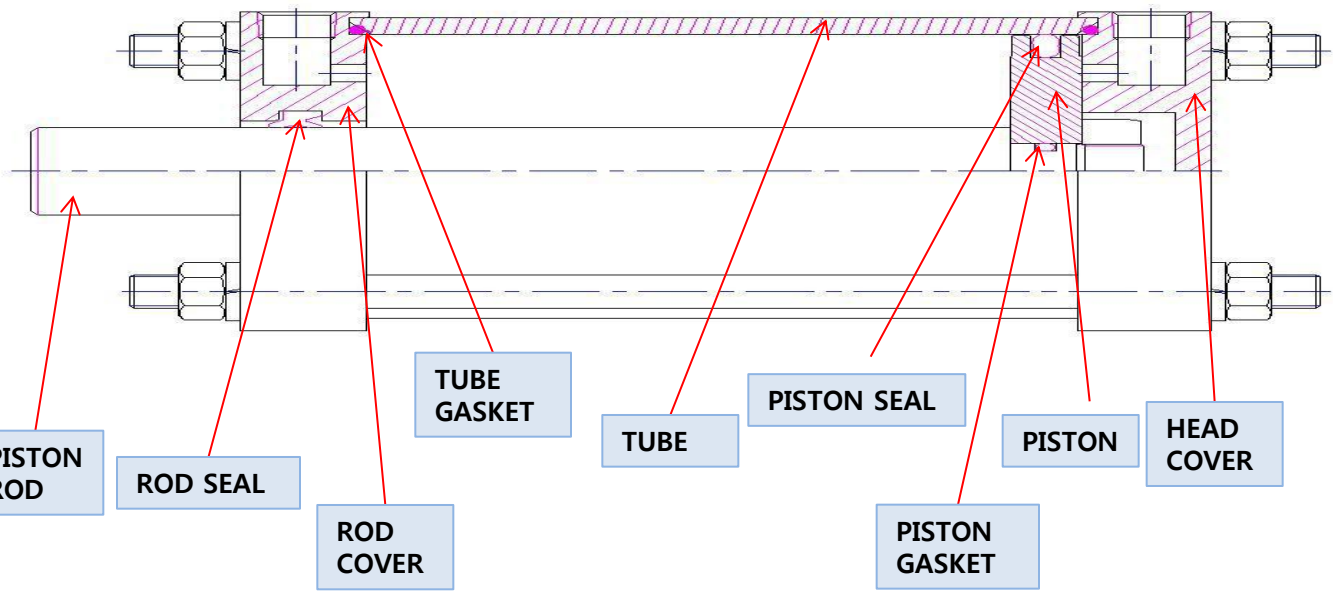

1. Structure





2. Maintenance

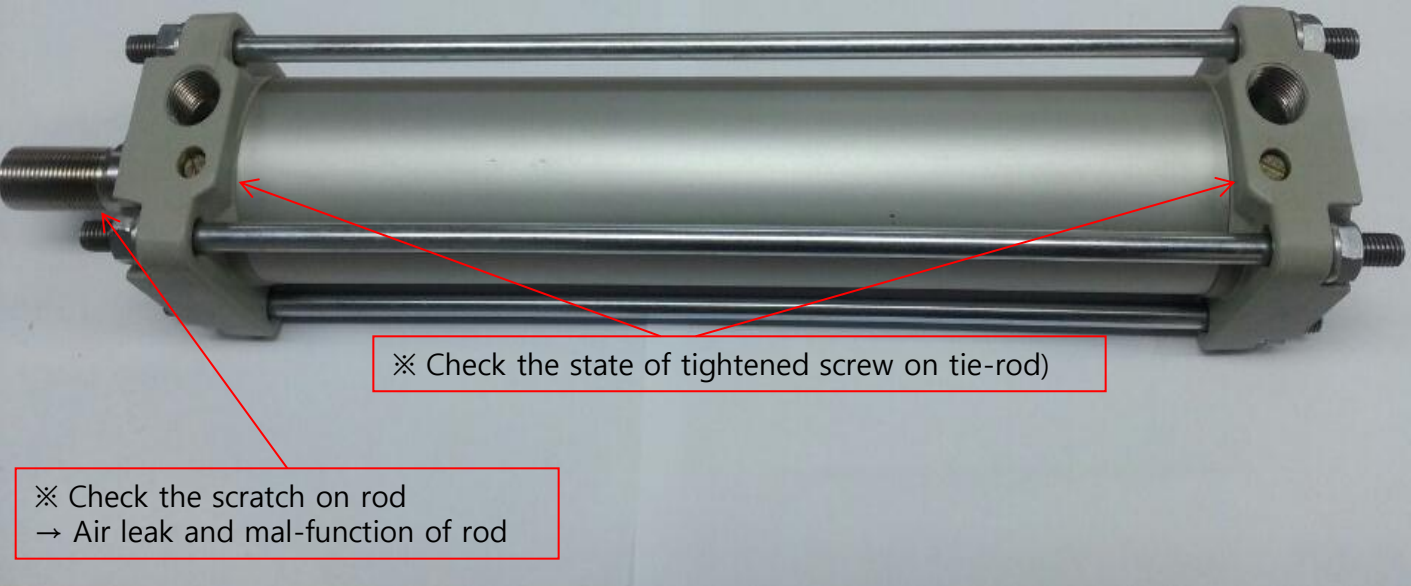

※ Check the state of tightened screw on tie-rod)

※ Check the scratch on rod
→ Air leak and mal-function of rod

※ Damaged tube : mal-functioning

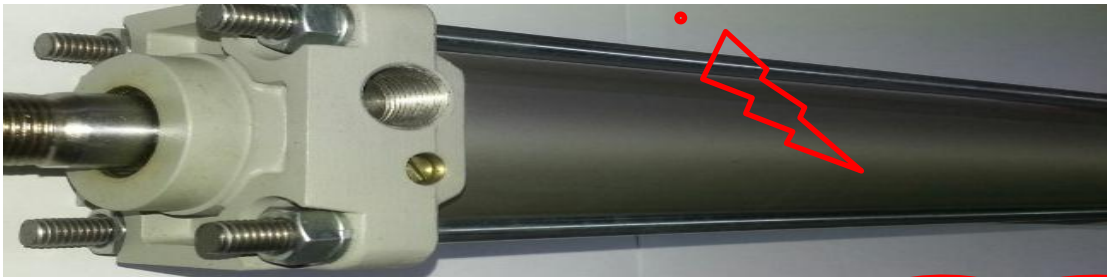

※ Over-payload can cause scratch on rod and air leak.

Payload





3-1. Dis-assembly



1) Fixing head cover, loosen nuts on tie-rod and take rod cover off.

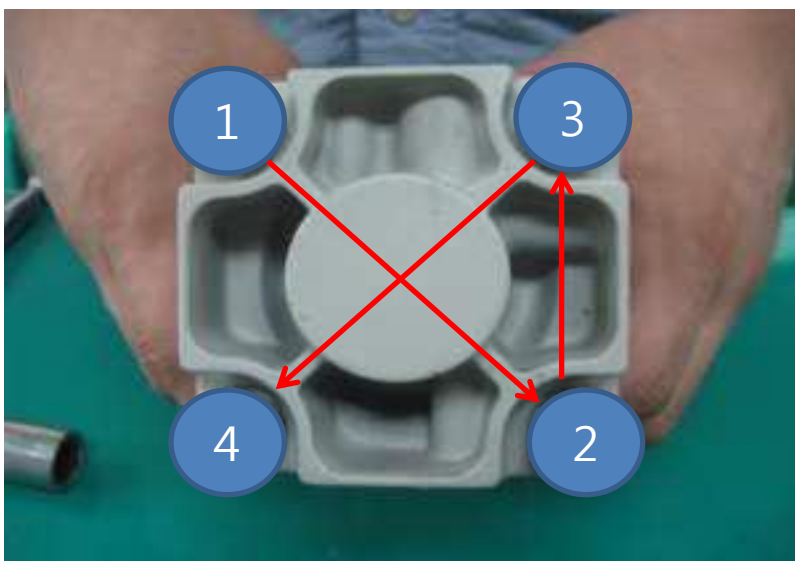

2) Loosen nuts ①②③④ in order on tie rod with socket wrench.
In case of AM2 series, L-wrench should be used.
Re-assembling, tightened nuts ①②③④ in order little by little.

3-2. Checking and replacing rod seal

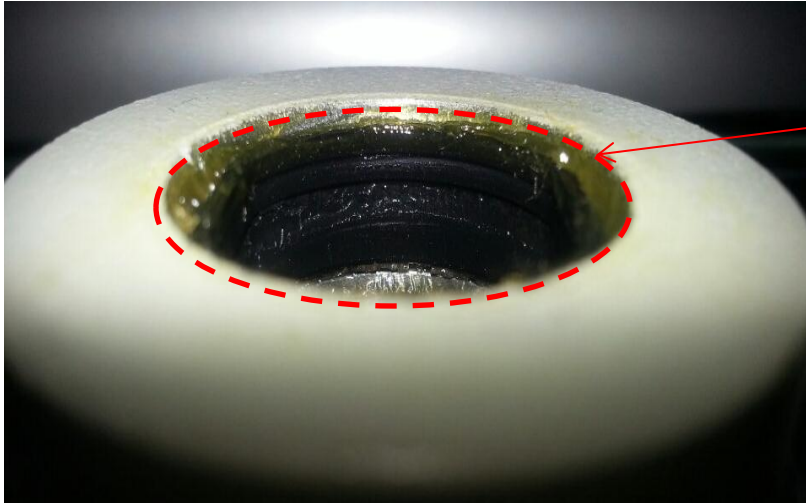

1) In case of air leak from rod cover, please check chips, distortion and amount of grease on rod seal.



2) Replacing rod seal, put enough grease on inside of seal. Before re-assembling, remove the old grease on rod cover. .



3-3. Replacing piston seal



1) In case of inner air-leak, please check distortion and damage on piston seal. Disassembling piston rod, please check the piston seal.



2) Replacing piston seal, please put suitable amount of grease on sealing parts. (Before replacing it, remove old grease)





3-4. Re-assembly

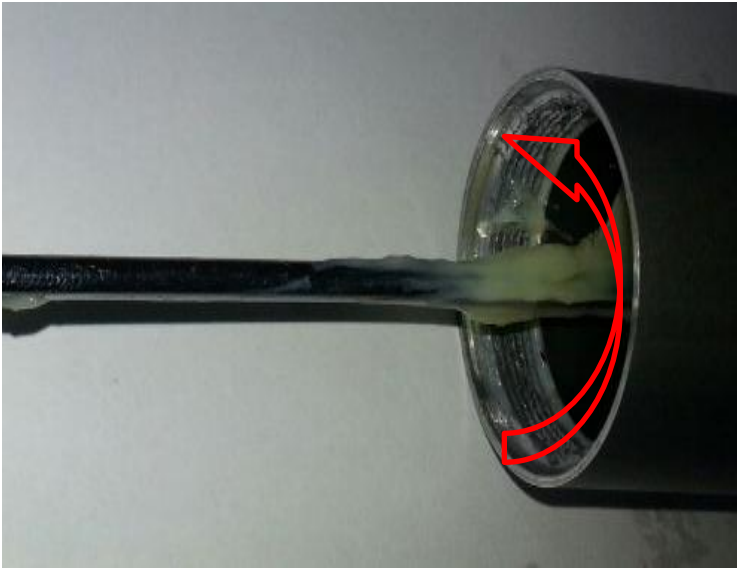

1) Before re-assembling, please check chips inside of tube and put the grease again. (Before assembling, remove old grease)

2) After checking rod and piston seal, please check that all parts are in good working order. Free of debris, dust or particles. Re-assemble in reverse order of disassembly.

Re-assembling should be done on surface plate to meet the flatness.

3-5. Caution



※ The protruded part on rod seal should be upper position like above picture. Otherwise, it could cause air leak.



1. Structure

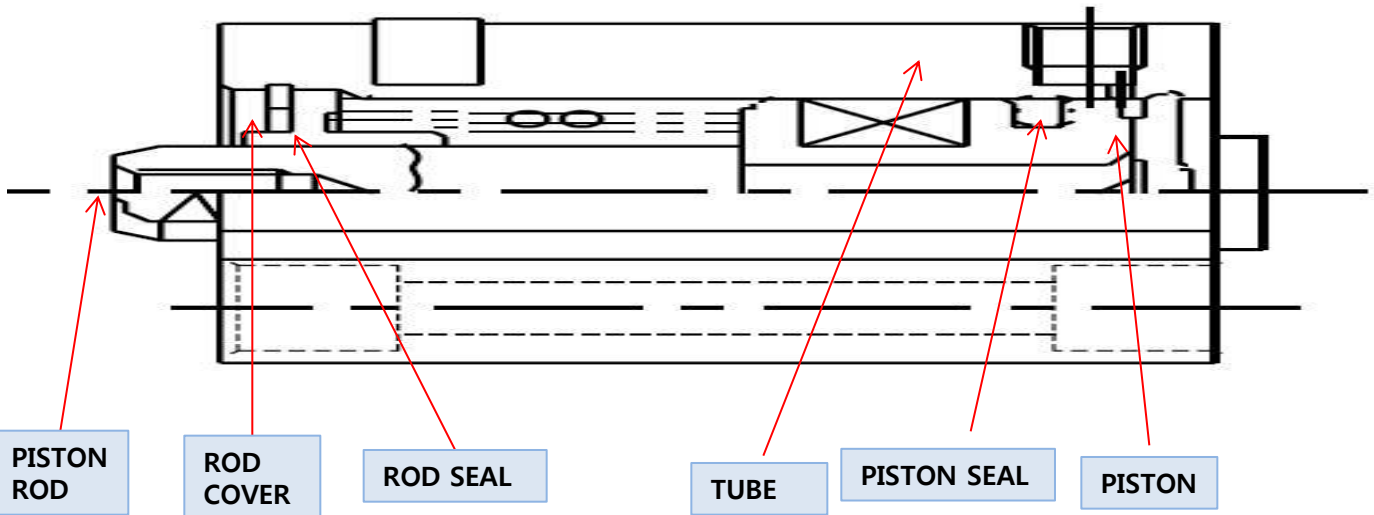
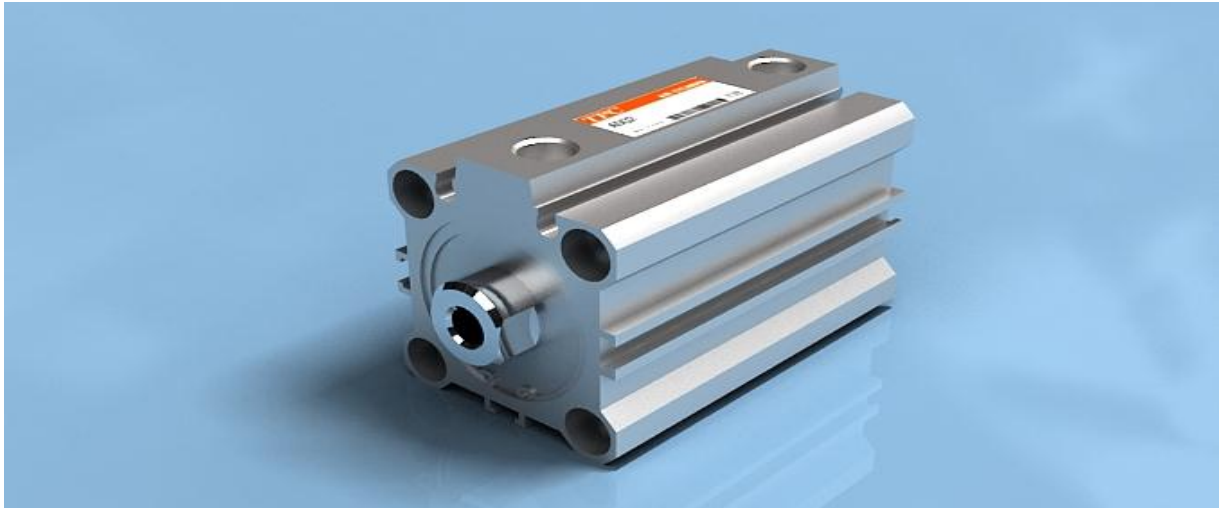

■ Features

1. Space saving cylinder
2. Easy dis-assembling by removing snap-ring.



2. Maintenance

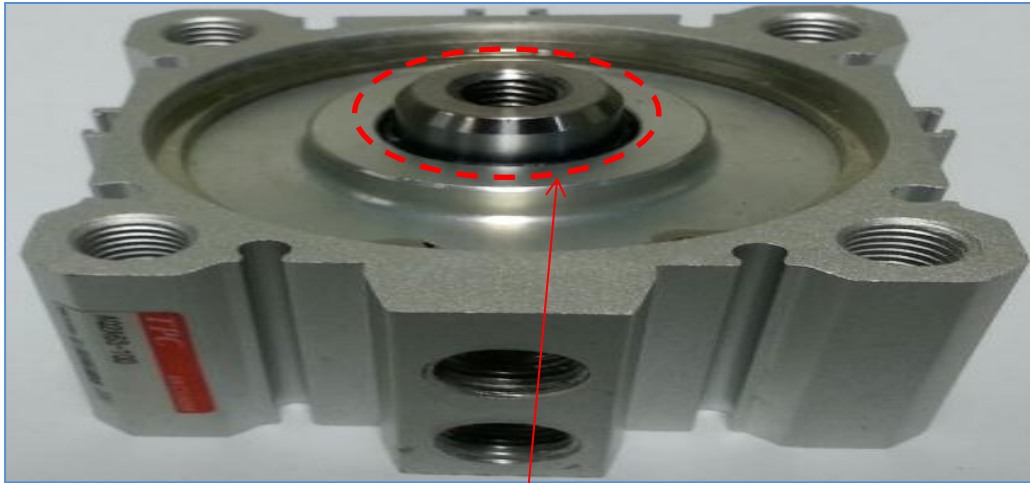

※ Please remove chips or dust in the space between rod seal and piston rod periodically in order to avoid abrasion on rod, stick-slip or air leak

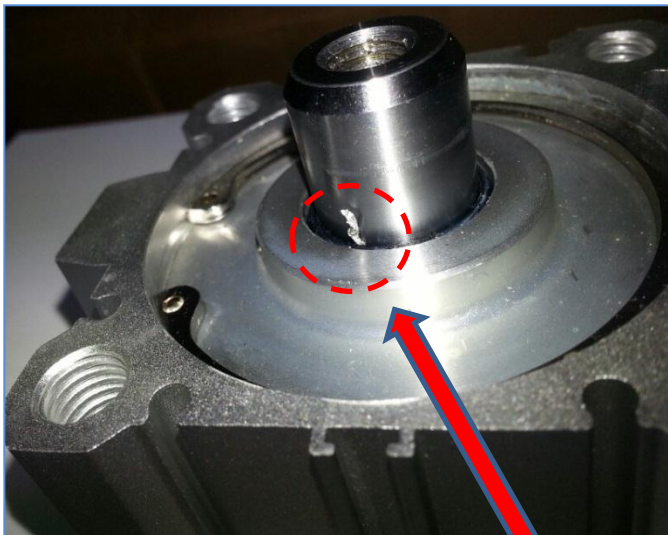

※ Please remove chips or dust periodically.

3-1. How to dis-assemble

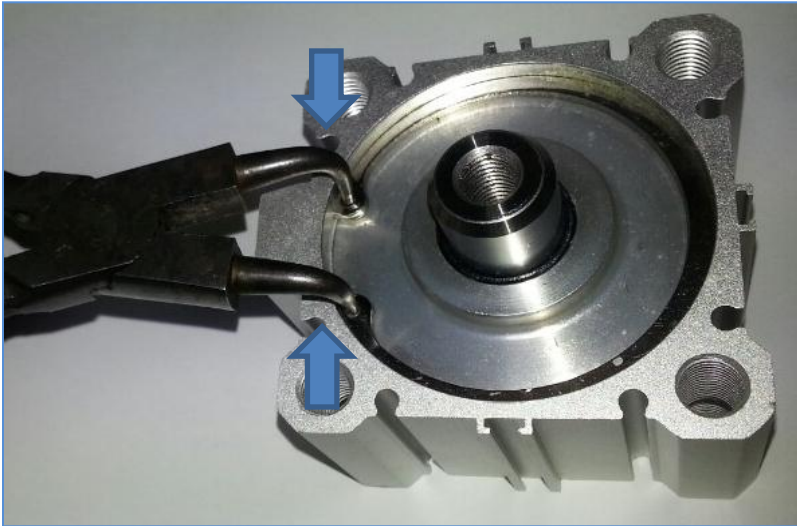

TUBE



ROD COVER ASS'Y

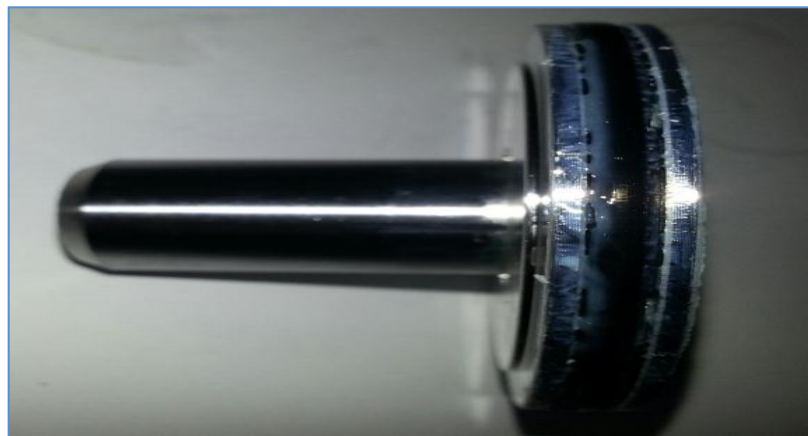

PISTON ROD ASS'Y

1) Remove snap-ring with snap-ring pliers.

2) TUBE : please check the inside of tube and clean it. In case of scratch inside, the tube should be replaced.

3) ROD COVER ASS'Y :
Please check the inside of rod cover and clean it. In case of scratch inside, the rod cover should be replaced.

PISTON ROD ASS'Y :
Please check surface and seal on rod. A scratched or distorted rod seal could cause air-leak.



3-2. Checking and replacing rod seal

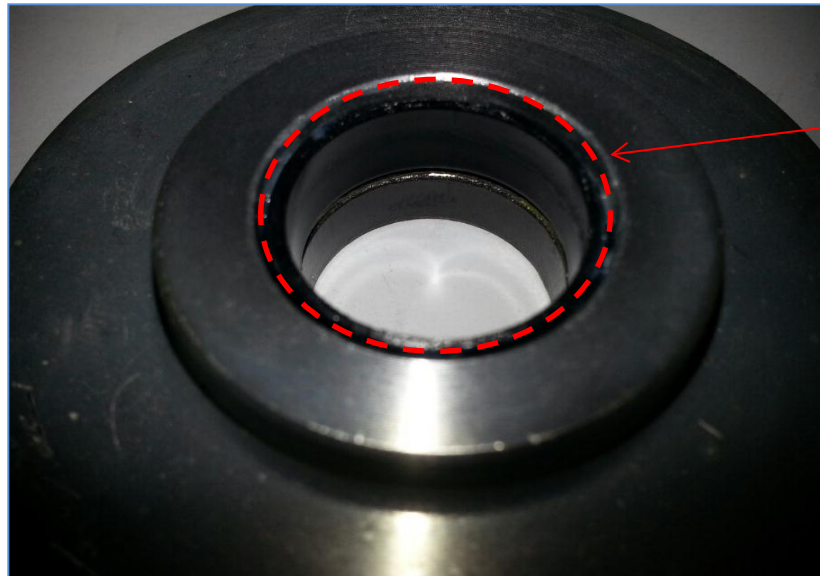

1) In case of air leak from rod cover, please check chips, distortion and amount of grease on rod seal. .

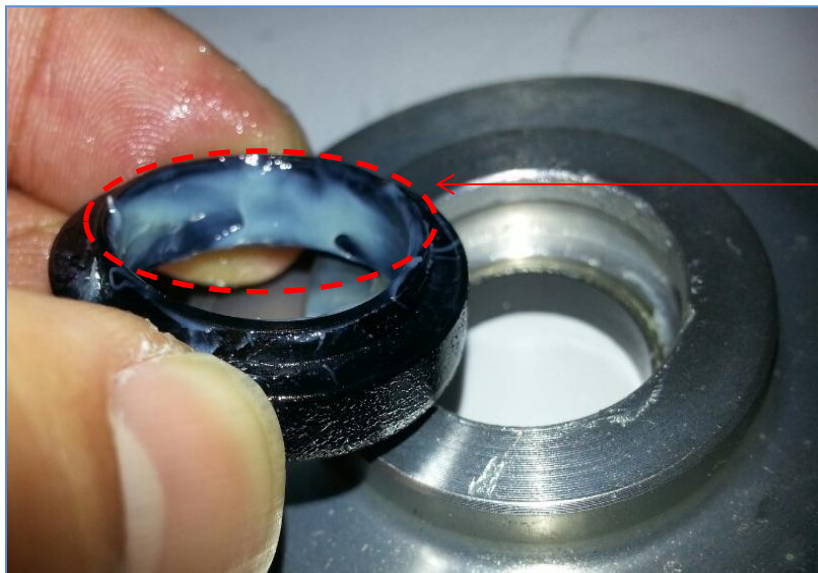

2) Replacing rod seal, put enough grease on inside of seal. Before re-assembling, remove the old grease on rod cover. .



3-3. Replacing piston seal

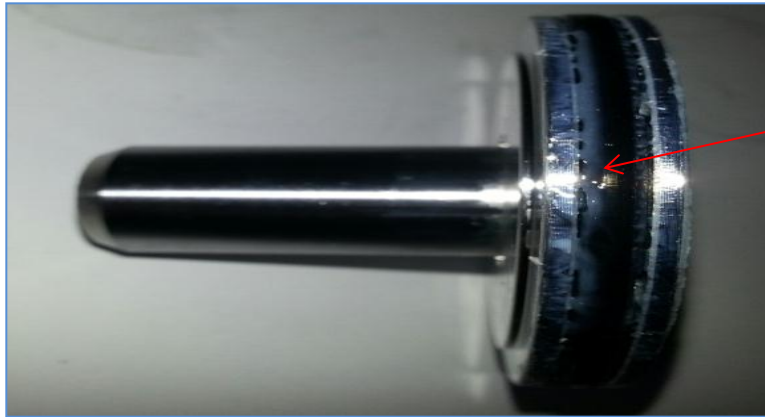

1) In case of inner air-leak, please check distortion and damage on piston seal. Disassembling piston rod, please check the piston seal.

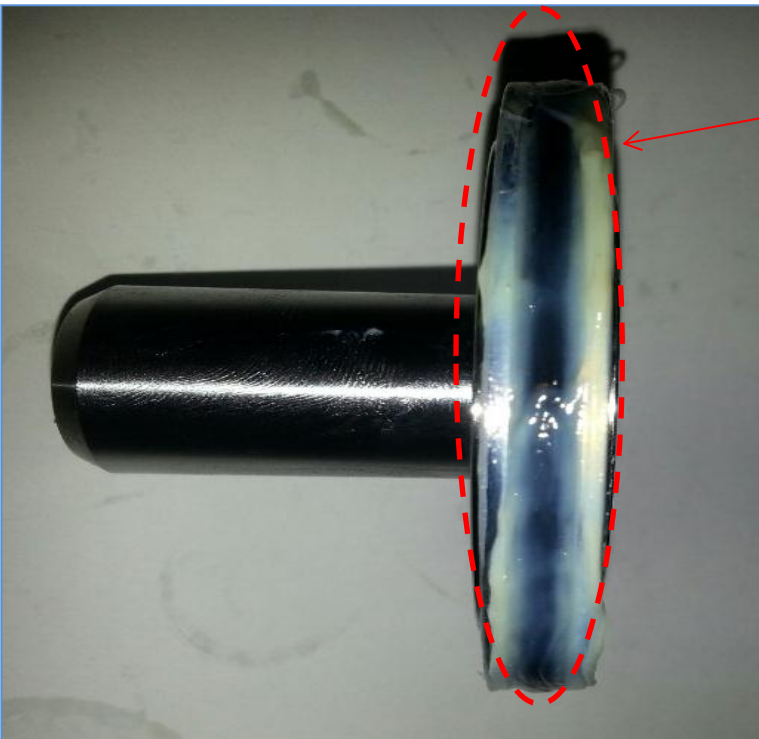

2) Replacing piston seal, please put suitable amount of grease on sealing parts. (Before replacing it, remove old grease)

3-4. Re-assembling

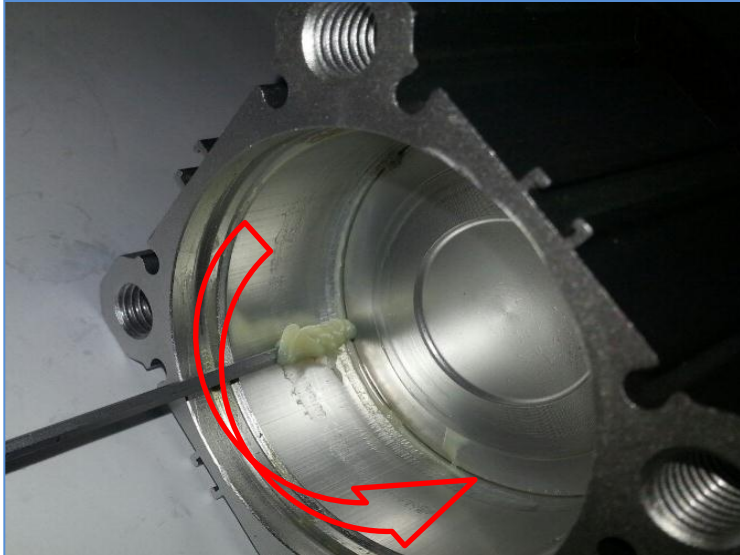

1) Before re-assembling, please check chips inside of tube and reapply the grease. (Before assembly, remove old grease)

2) After checking rod and piston seal, please check that all parts are in good working order. Free of debris, dust or particles. Re-assemble in reverse order of disassembly.



3-5. Caution



※ The protruded part on rod seal should be upper position like above picture. Otherwise, it could cause air leak.



※ Flat-surface on snap-ring should be shown(upper position).



1. Structure

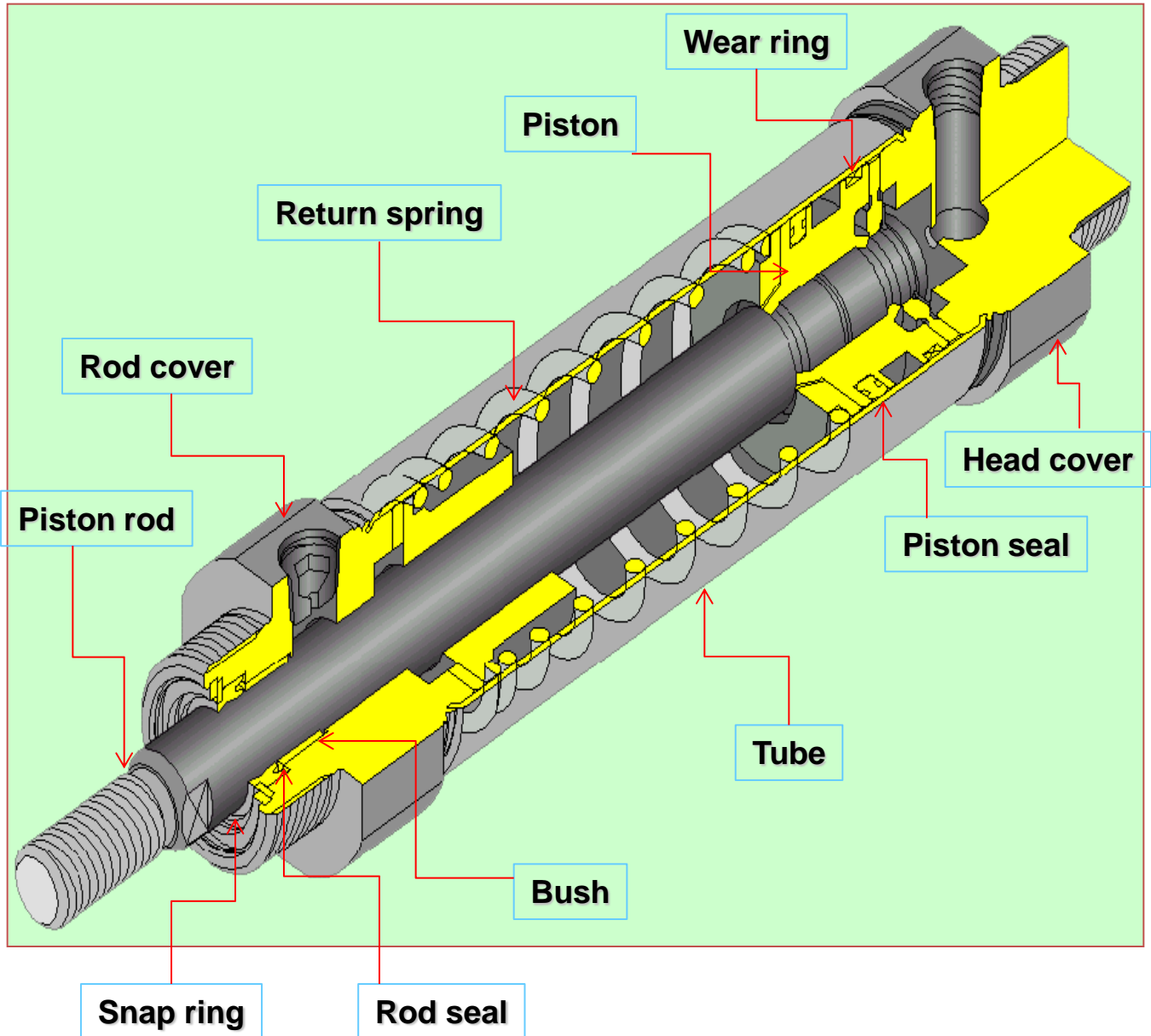



2. Maintenance

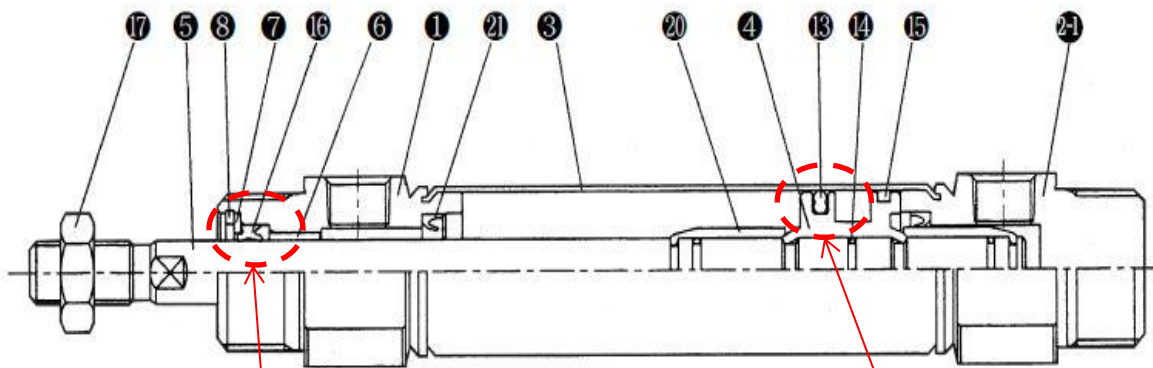
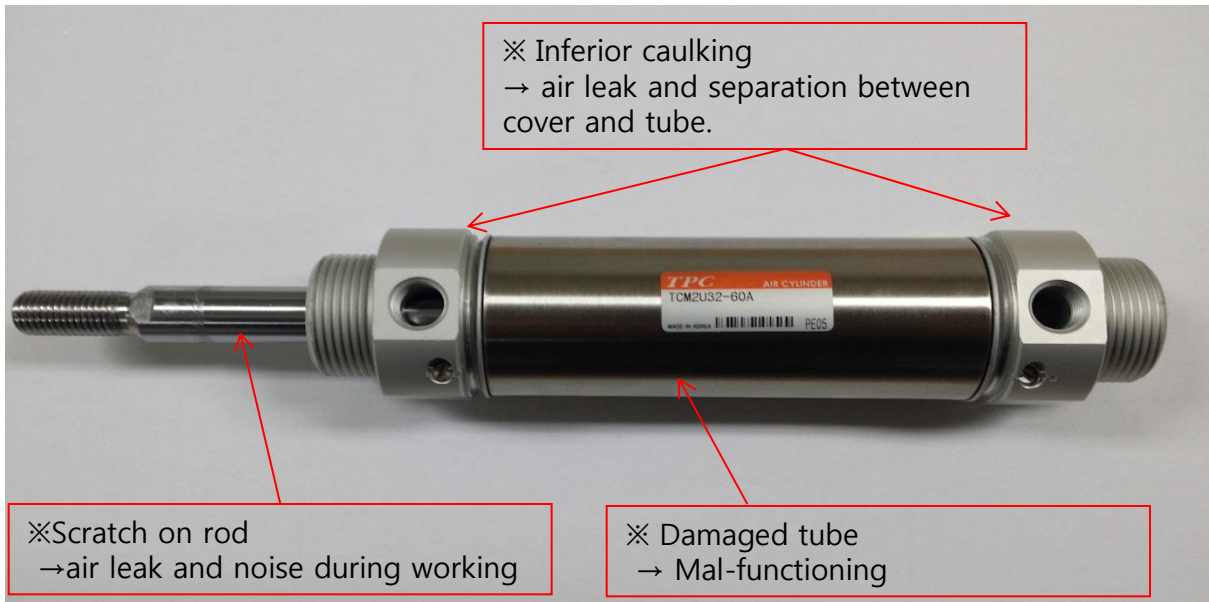

※ Faulty rod-seal
→ Inflowing particles and outer air leak.
→ Replaceable.

※ Twisted or damaged piston seal
→ Inner air leak.
→ Not replaceable.

How to replace rod seal



1) ACP and AX series is assembled by caulking, so it's not possible to disassemble rod cover and head cover from tube, but rod seal can be replaced.



2) Remove snap ring with snap ring pliers.



3) Remove snap-ring, seal washer and rod seal in order.



4) Re-assemble new rod seal, seal washer and then snap-ring in order.

3. Case study

1. **Company** : PNE

2. **Item no** : AXF32-150

3. **Problem** : Breakaway of snap ring and rod seal

4. **Root causes**

- a. Breakaway of snap ring : faulty assembly of snap ring
- b. Breakaway of rod seal : not enough grease

5. **Checking**



6. **Corrective actions**

- a. Snap ring – assembling on the jig.
- b. Rod seal – adding grease.

1. Structure

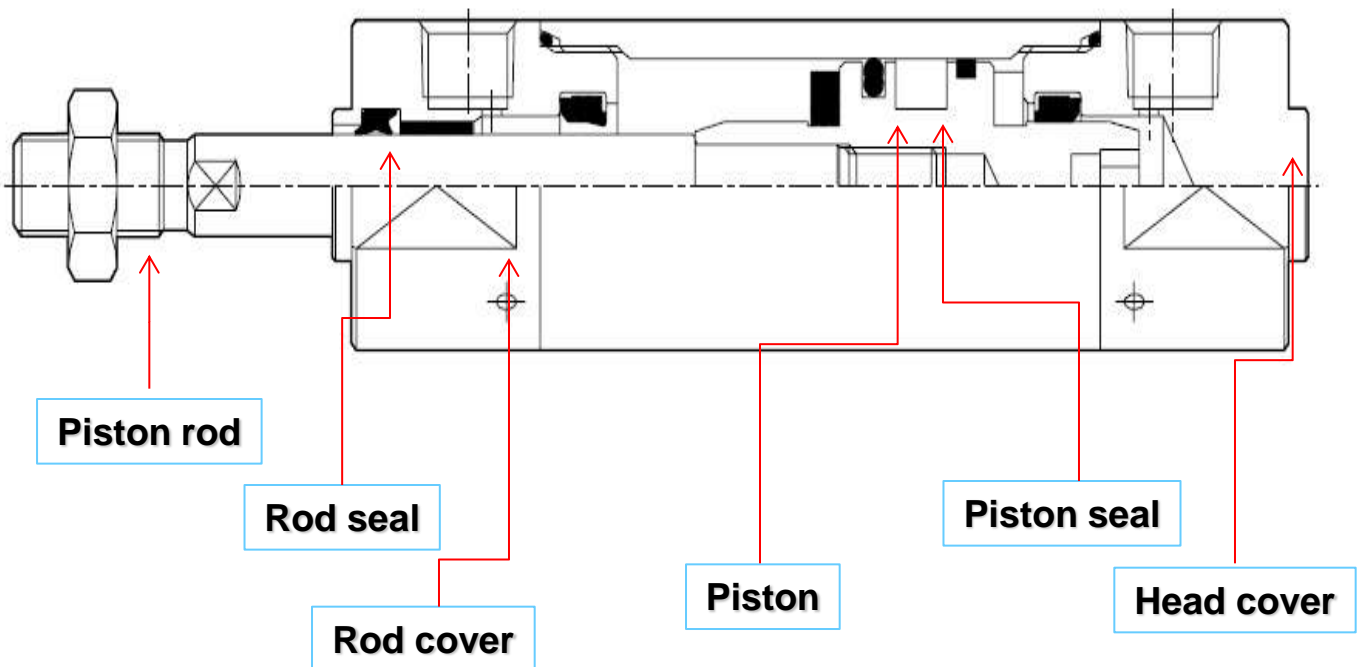

A. Sales points

- 1) High speed
- 2) Compact type
- 3) Tightened screw type between cover and tube, so it can be disassembled.

B. Frequent trouble shooting case

: Early damaged cushion seal

- ▶ Root cause : over-payload
- ▶ Corrective actions : replacing cushion seal, changing speed and adjusting cushion valve.

2. Maintenance.

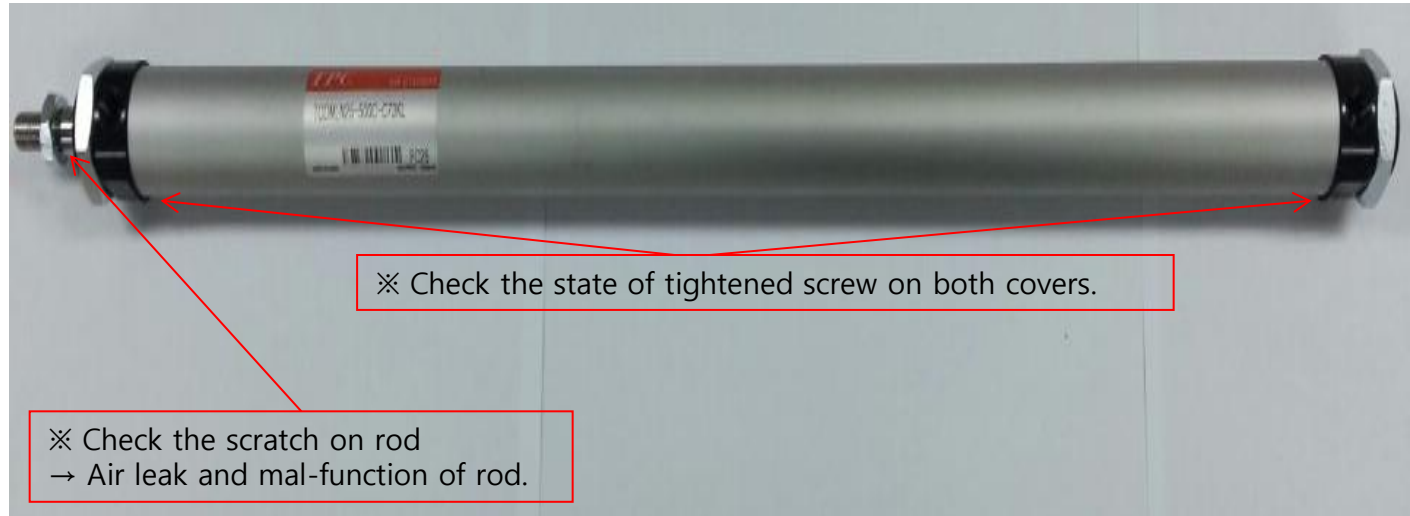

※ Damaged tube :
mal-functioning

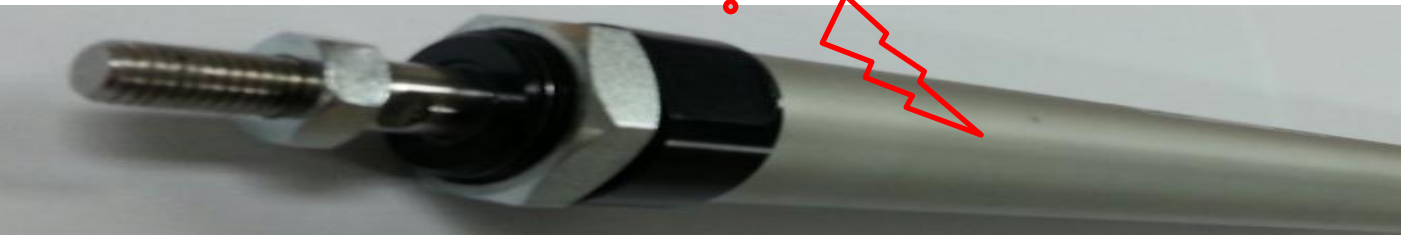

※ Over-payload can cause scratch on
rod and air leak.

Payload

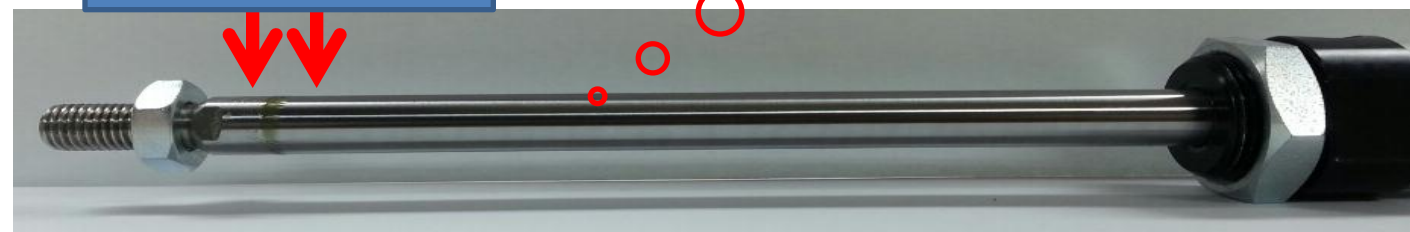



3-1. Replacing rod seal



1) Gently hold head cover at spanner flats with a vice and loosen rod cover by turning counterclockwise with a spanner or monkey wrench.



2) In case of air leak from rod cover, please check chips, distortion and amount of grease on rod seal.



3) Replacing rod seal, put enough grease on inside of seal. Before re-assembling, remove the old grease on rod cover.



3-2. Replacing piston-seal



1) In case of inner air-leak, please check distortion and damage on piston seal. Disassembling piston rod, please check the piston seal.



2) Replacing piston seal, please put suitable amount of grease on sealing parts. (Before replacing it, remove old grease)



3-3. Re-assembly

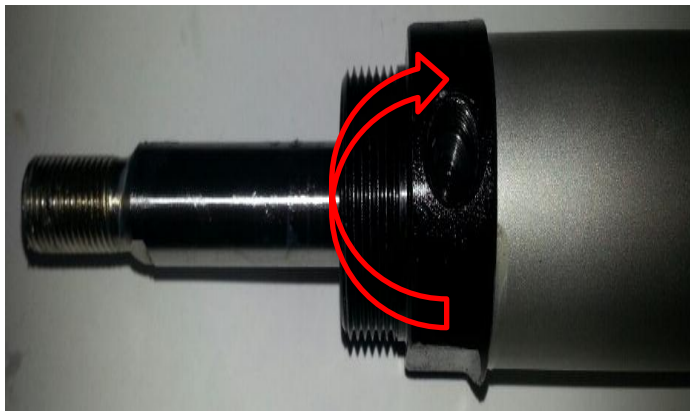
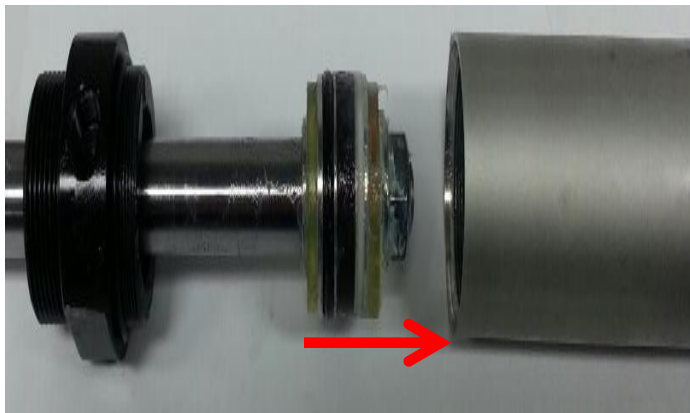
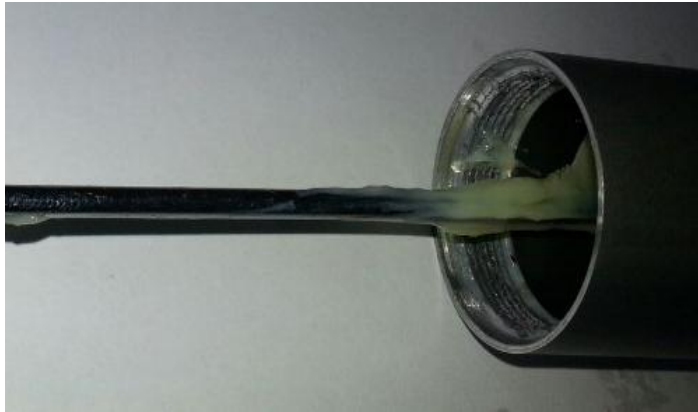

1) Before re-assembling, please check dust inside of tube and put the grease again. (Before assembling, remove old grease)

2) Please insert piston rod to the direction on the red arrow smoothly to avoid scratch on piston seal.

3) Gently hold head cover at spanner flats with a vice and re-assemble rod cover by turning clockwise with a spanner or monkey wrench.

3-4. Caution



※ The protruded part on rod seal should be upper position like above picture. Otherwise, it could cause air leak.



1. STRUCTURE

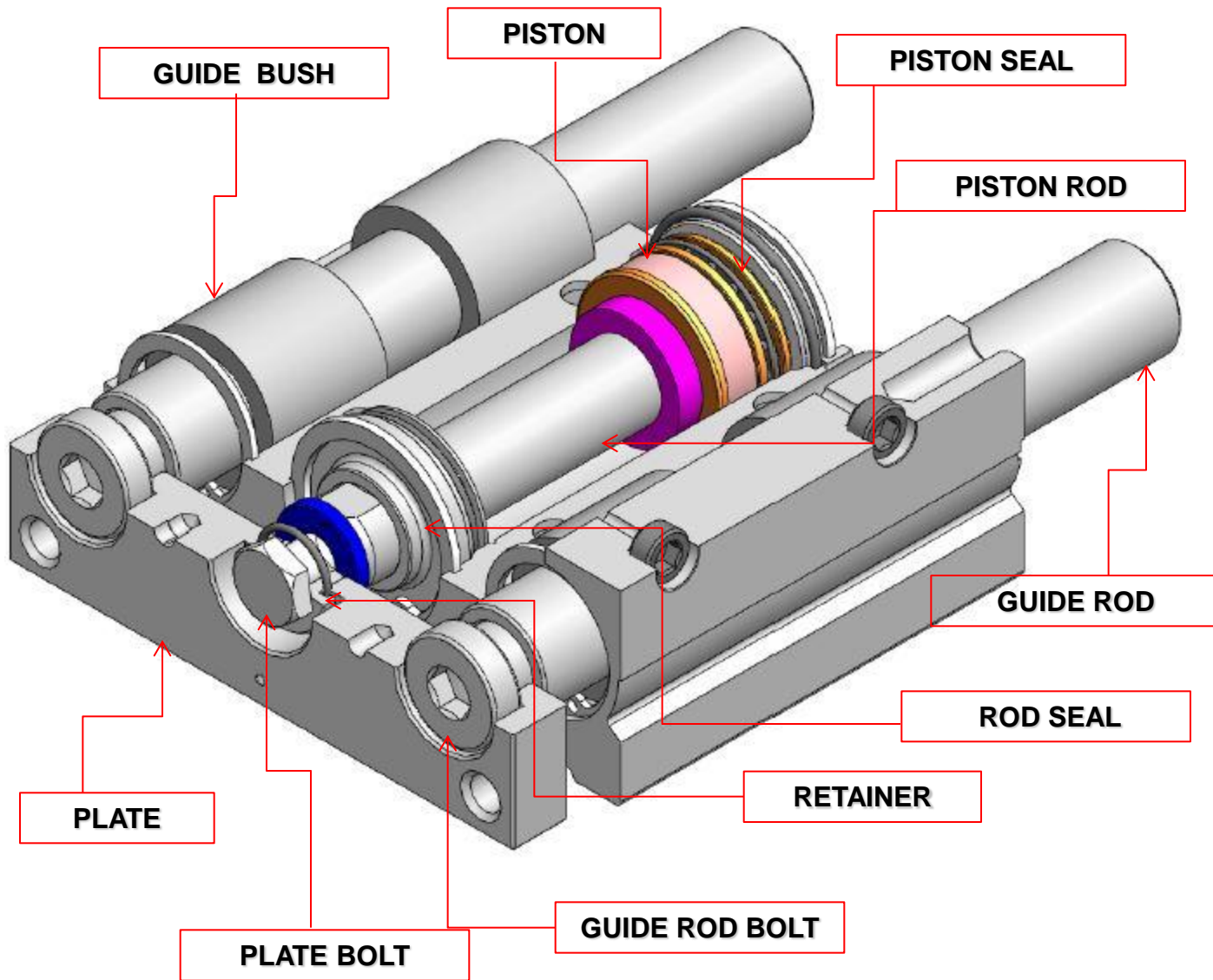



2. MAINTENANCE

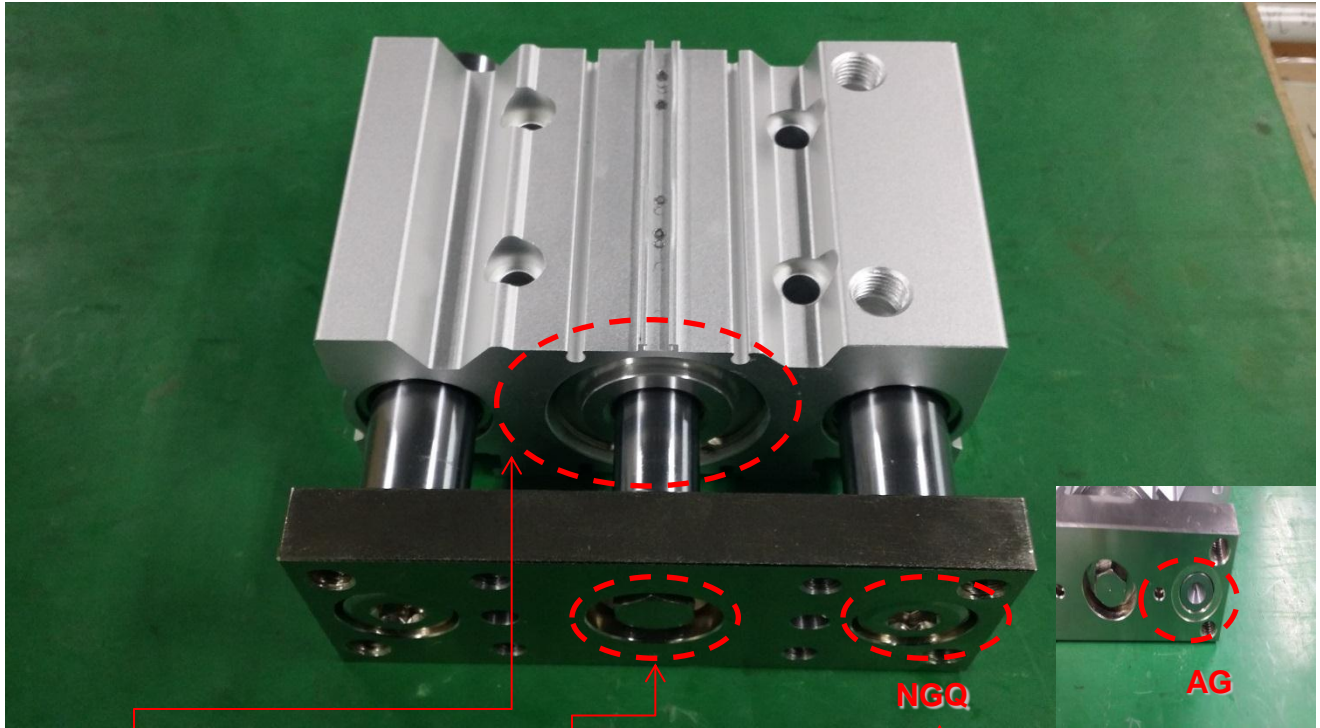

※ PLATE BOLT

1. Easy to disassemble(plate ass'y)
2. Built-in floating function

※ ROD COVER

After disassembling rod cover, rod seal and piston seal can be replaced.

※ Different type of guide rod

1. NGQ – bolt up type (dis-assembly available)
2. AG – caulking type (dis-assembly not available)

a. How to dis-assemble the plate

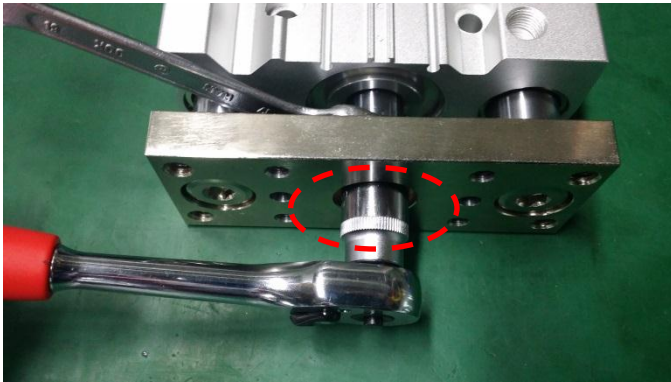

1) Loosen plate bolt with spanner and socket wrench.

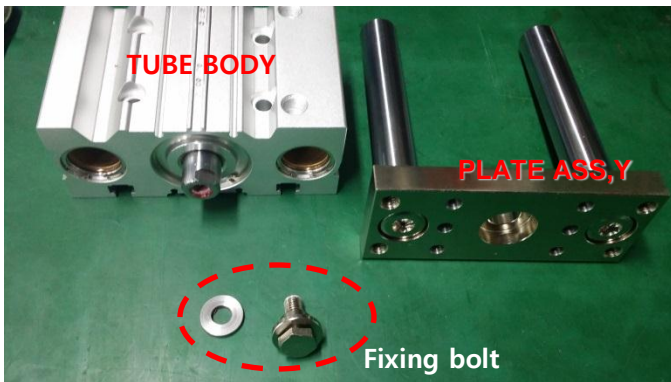

2) Dis-assemble the plate ass'y from tube body.

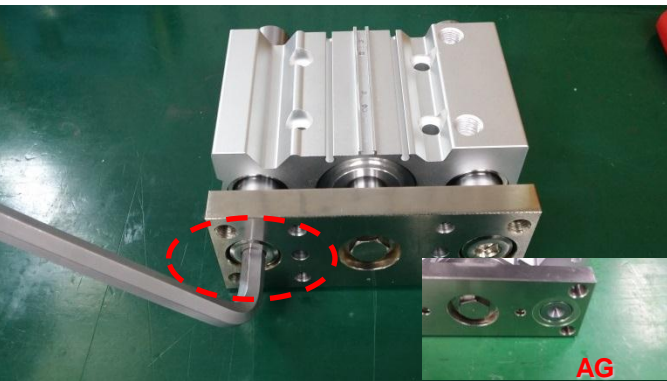

3) The guide rod of NGQ can be dis-assembled.

Note : The guide rod of AG can not be dis-assembled.

b. How to replace seals and gasket



1) Remove snap-ring with snap-ring pliers from rod cover.



2) Cover gasket, rod seal and piston seal can be replaced.

1. Structure

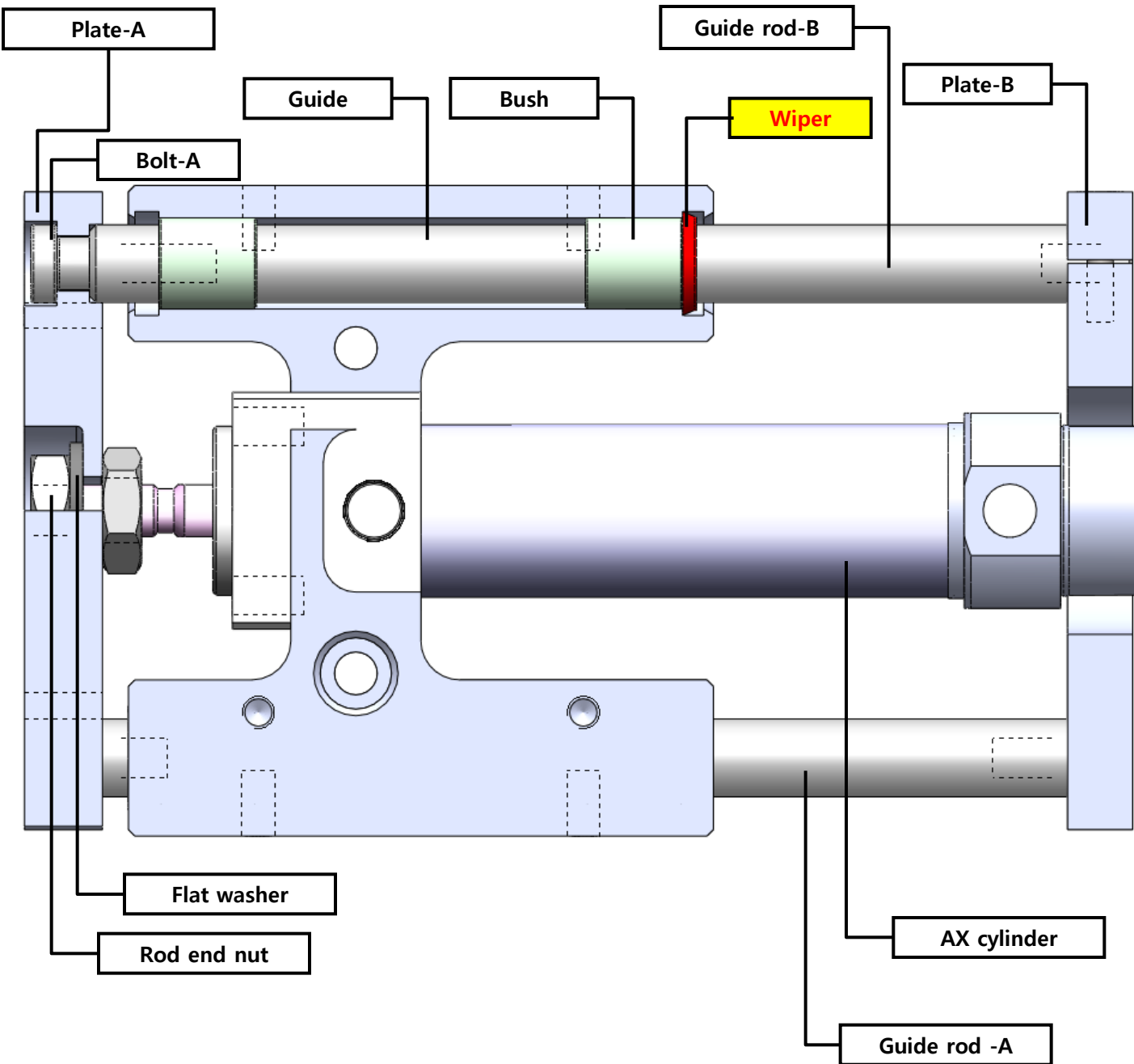



2. Maintenance

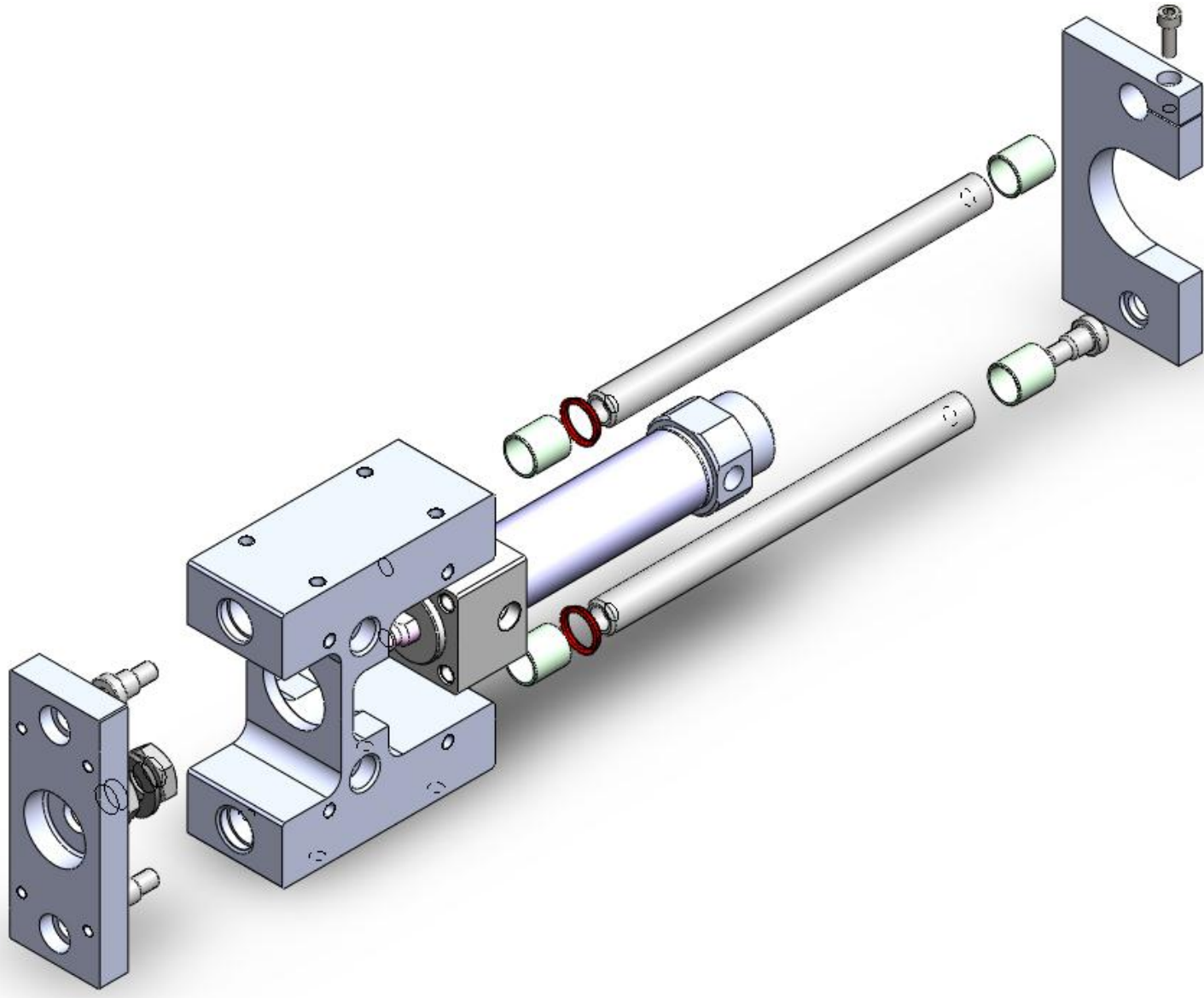

※ Note : The replacement of seals is the same as AX series.

a. How to remove old wiper

- Remove old wiper with small screw driver. Be careful **not to make scratch on the groove of wiper.**

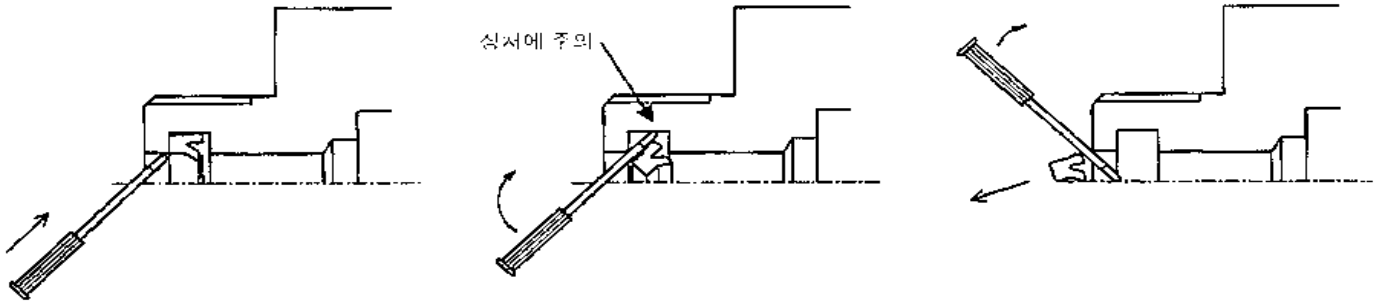

b. How to replace to new wiper

- Be careful not to put wiper in wrong direction. After replacing it, please apply grease evenly.

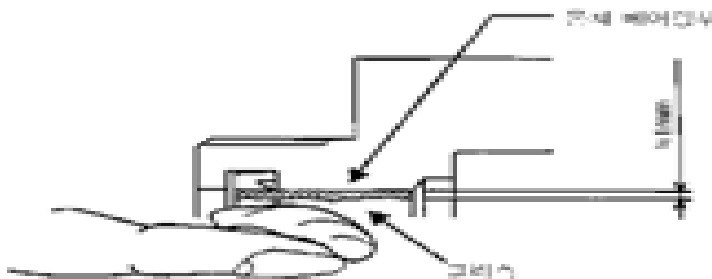



1. Structure

[NLCD]

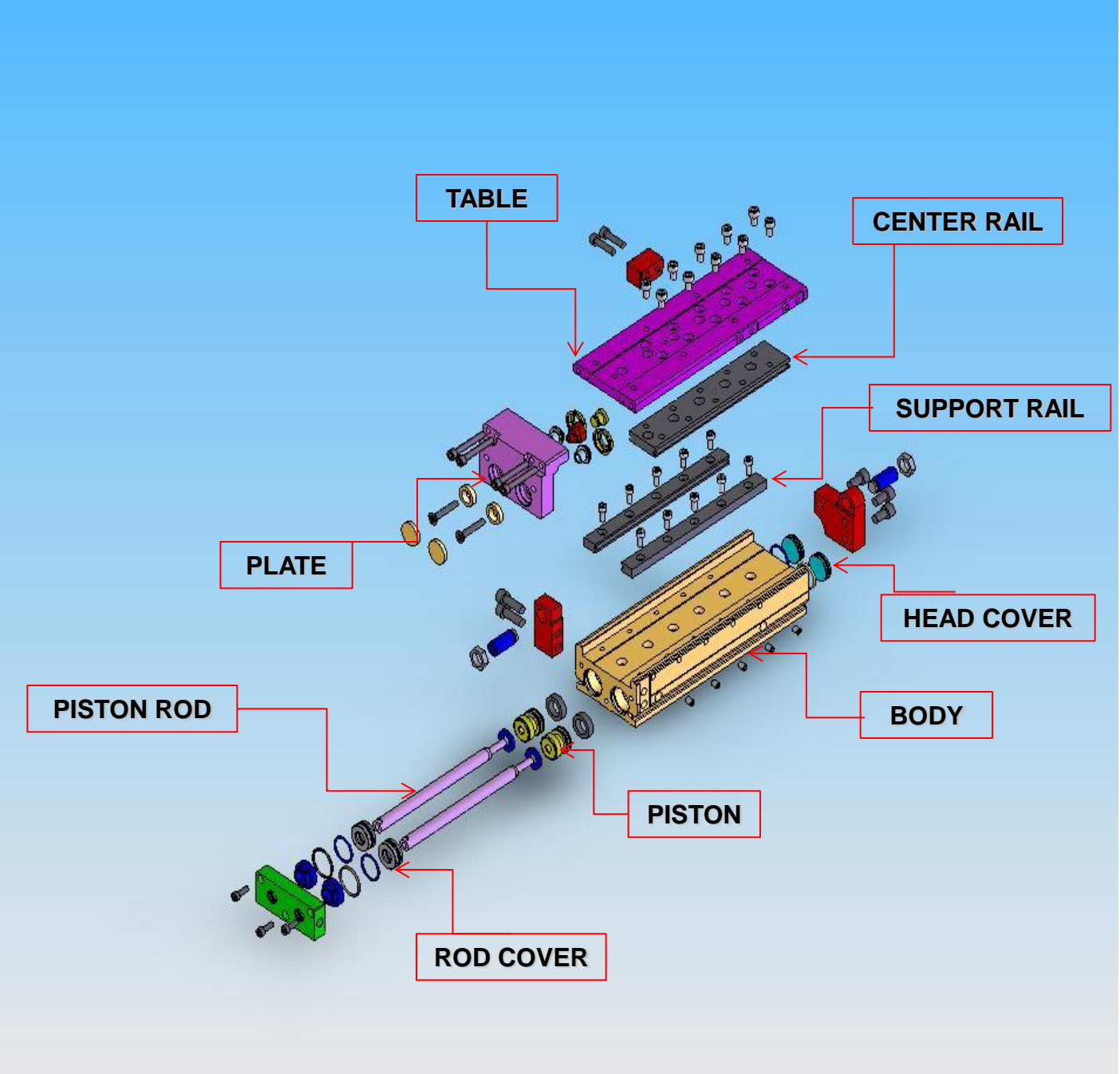

[NLCS]

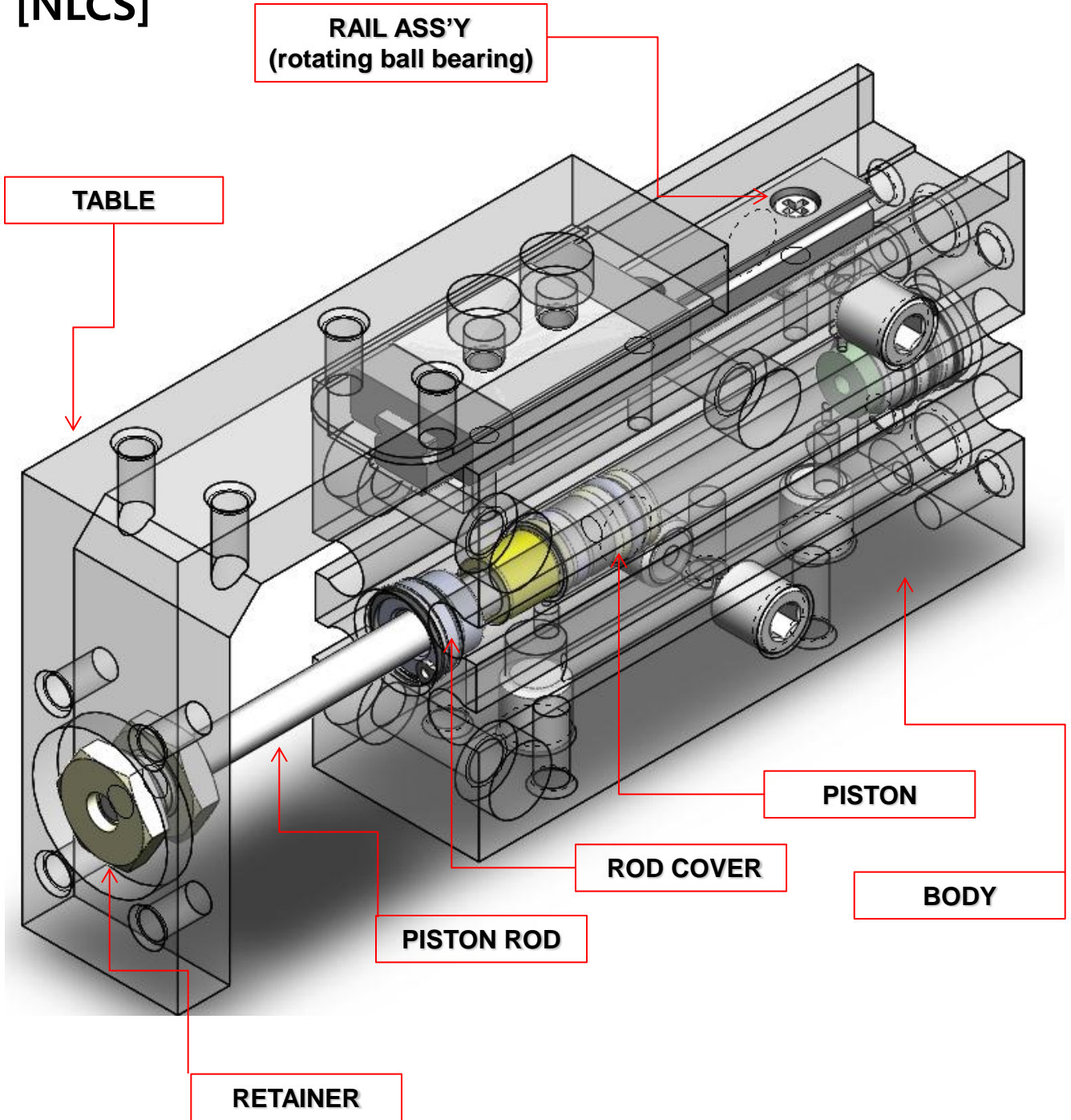



3. Maintenance

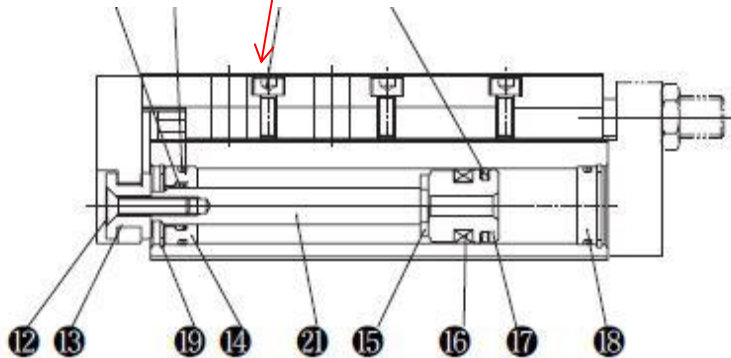
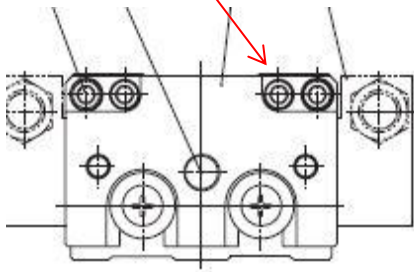
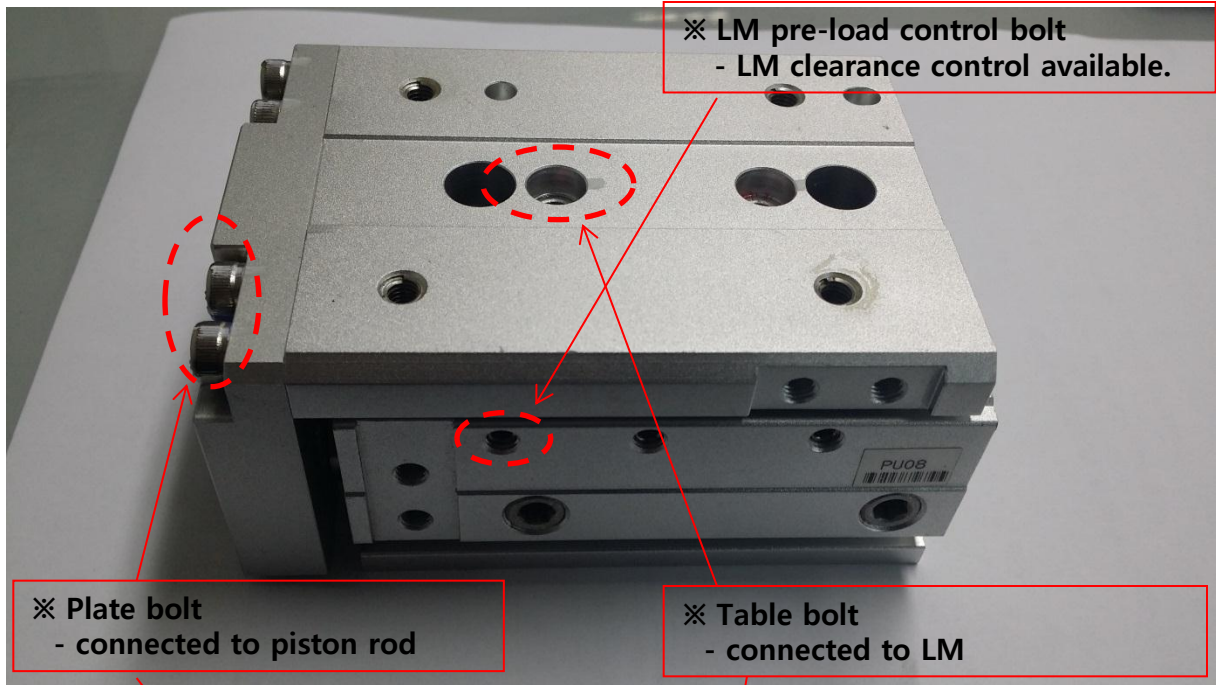

A. How to adjust pre-load of LM

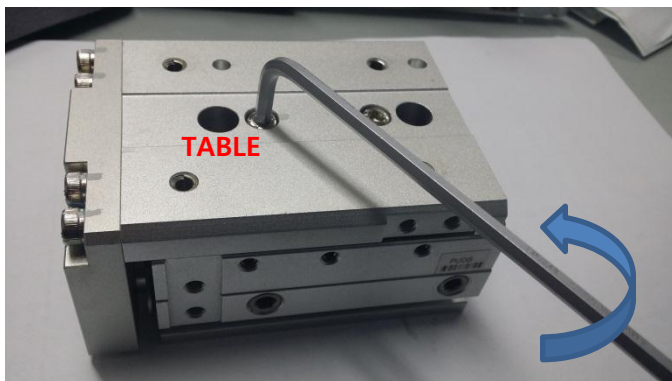

1) Turn table bolt counterclockwise with L-wrench and take off the table.

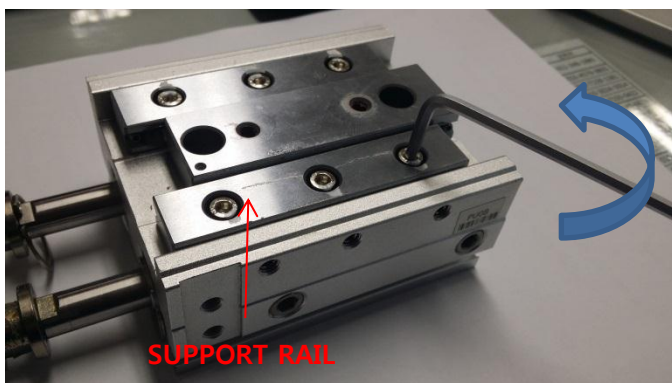

2) Loosen the bolt in half on support rail.
Note : Do not release bolt fully.

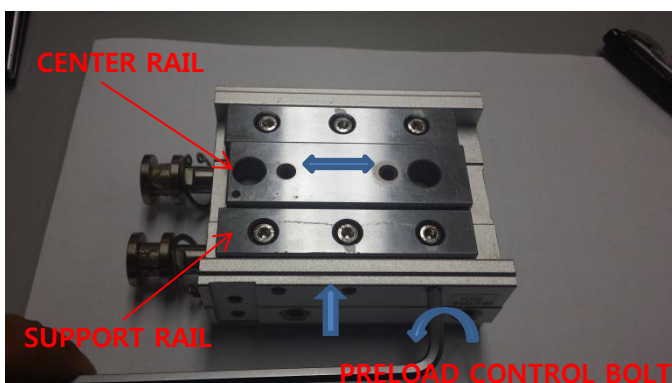

3) a. Loosen preload control bolt little by little.

b. Moving the center rail from side to side and the support rail back and forth, adjust clearance(preload) and fix it.

B How to replace seals and gasket



1) Loosen rod cover by turning counterclockwise with L-wrench and take off rod cover.

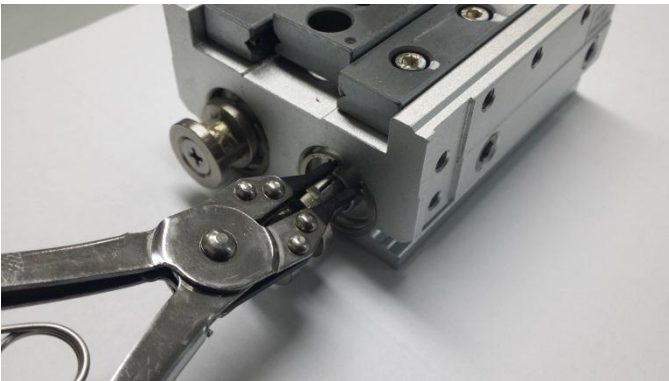

2) Remove snap-ring with snap-ring pliers.



3) Cover gasket, rod seal and piston seal can be replaced.

1. Structure

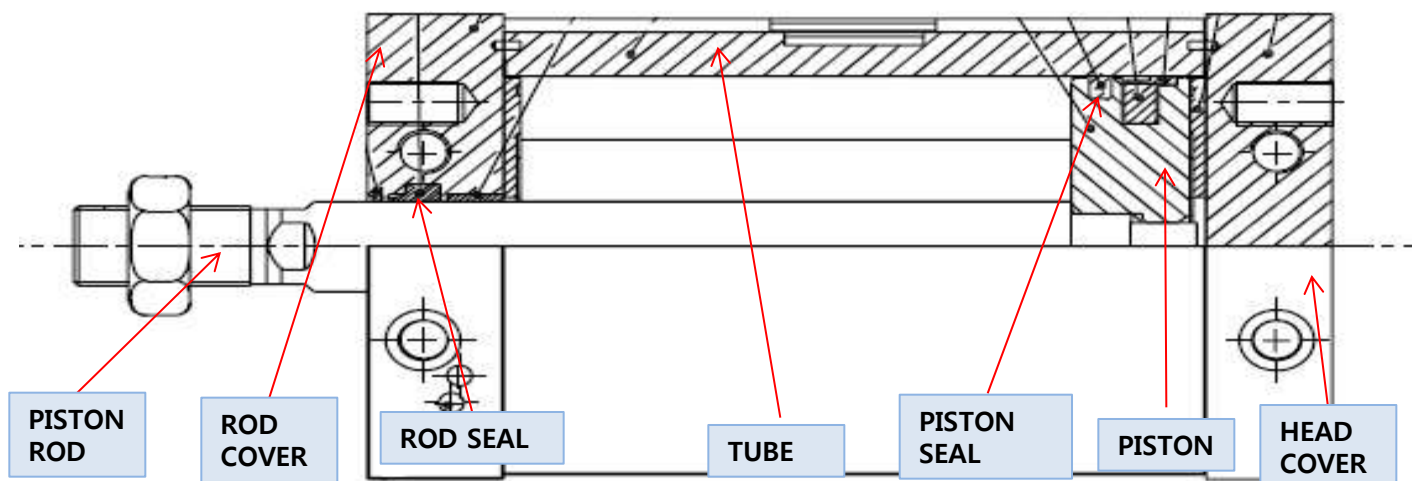

■ Features

- 1) Space saving
 - 2) Built in speed controller
 - 3) Built in coil scraper for welding lines
- ※ Rod seal and piston seal replaceable.

2. Maintenance



※ Please remove chips or dust in the space between rod seal and piston rod periodically in order to avoid abrasion on rod, stick-slip or air leak.

3-1. Dis-assembly

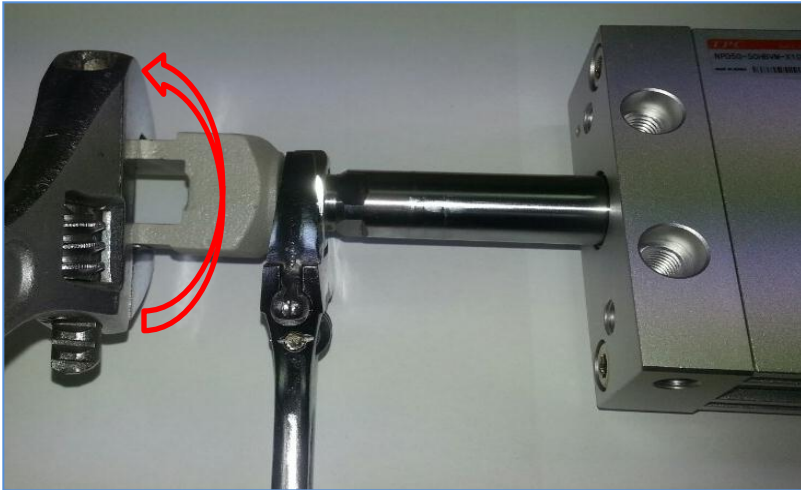

1) Gently hold rod at spanner flats and loosen Y-knuckle by turning counterclockwise with a spanner or monkey wrench. Be careful not to scratch the rod.



2) Loosen rod cover by turning counterclockwise with L-wrench and take off the rod cover.

3-2. Replacing rod seal

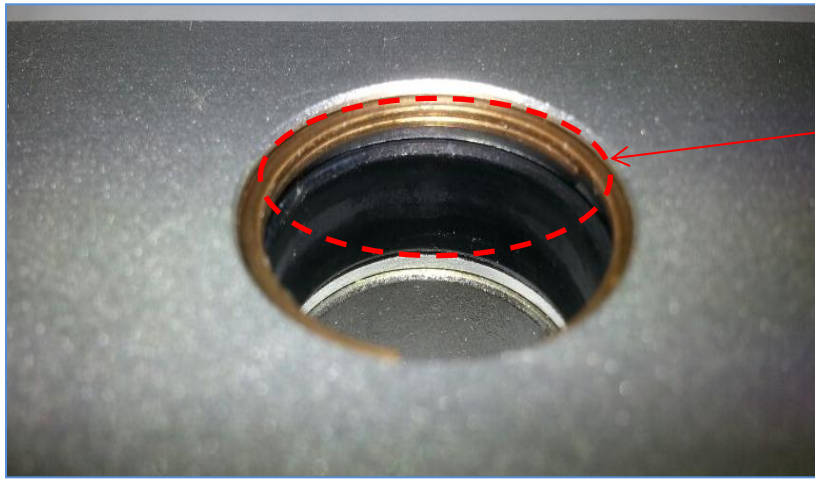

1) In case of air leak from rod cover, please check chips, distortion and amount of grease on rod seal.



2) Replacing rod seal, put enough grease on inside of seal. Before re-assembling, remove the old grease on rod cover.



3) Insert rod seal as shown in the left picture.



3-3. Replacing piston seal



1) In case of inner air-leak, please check distortion and damage on piston seal. Disassembling piston rod, please check the piston seal.



2) Please remove chips or dust on piston and piston rod periodically in order to avoid abrasion on rod, stick-slip or air leak

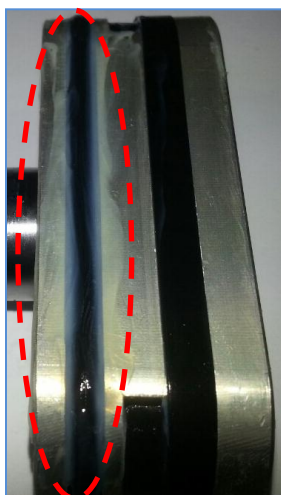
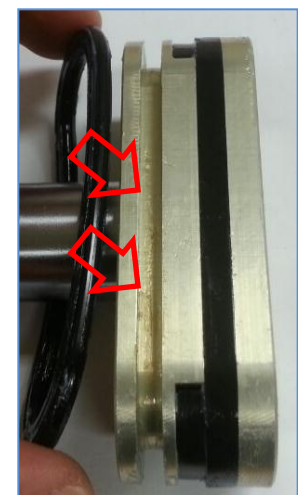

3) Replacing piston seal, please put suitable amount of grease on sealing parts. (Before replacing it, remove old grease) and replace it as shown a left picture.

4) After replacing piston seal, please apply grease to entire piston seal evenly.

3-4. Re-assembly

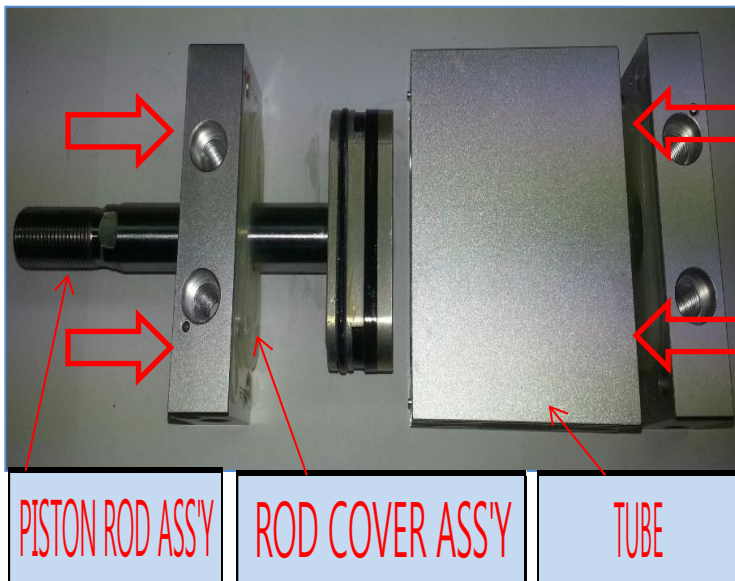
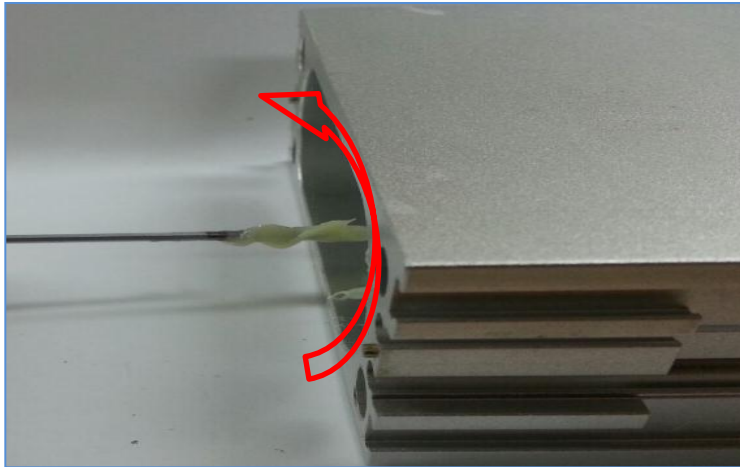

1) Before re-assembling, please check chips inside of tube and put the grease again. (Before it, remove old grease)

2) After checking rod and piston seal, please check if all parts are ok.
Re-assemble in reverse order of dis-assembly.

3-5. Caution



※ The protruded part on rod seal should be upper position like above picture. Otherwise, it could cause air leak

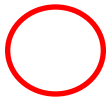

※ Be careful not to block exhaust hole with bumper in both rod and head cover.

1. STRUCTURE

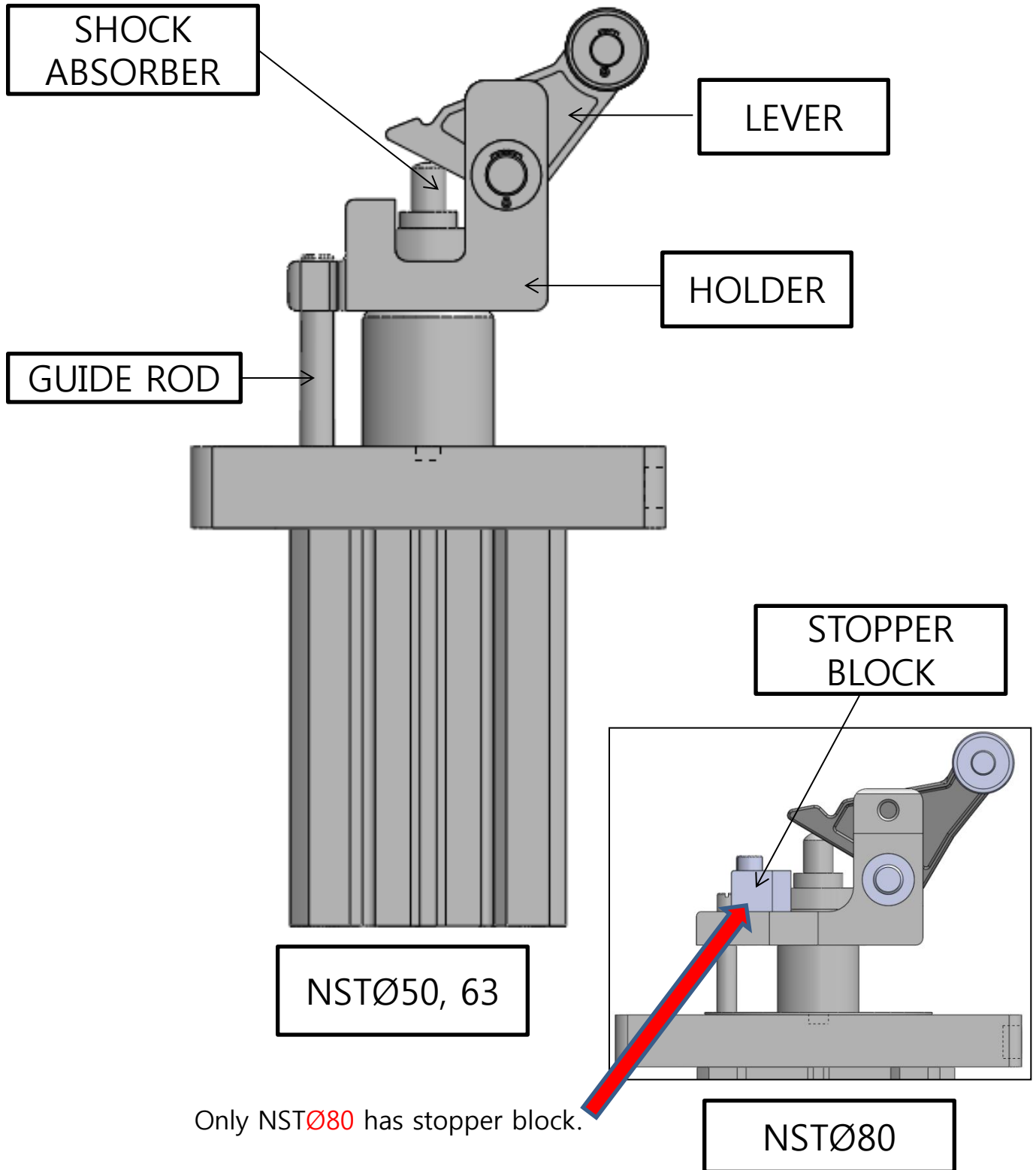

2. How to change SHOCK ABSORBER (NSTØ50,63)

1) Loosen the hex bolt with wrench on stopper holder and release lock nuts(M5).



VIEW A

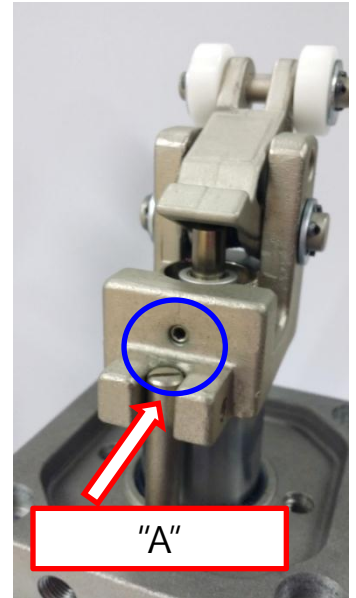

2) Lean the lever to 90° and pull shock absorber.

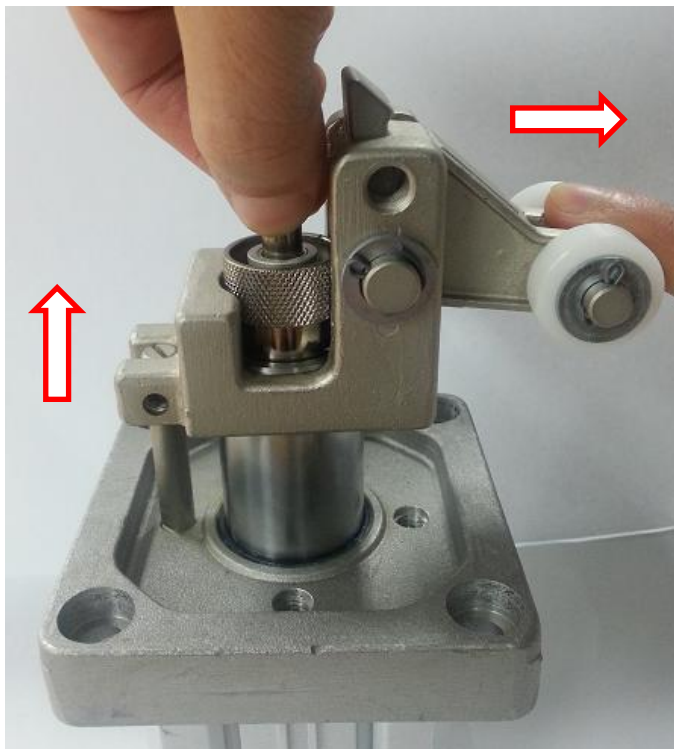

3. How to change SHOCK ABSORBER (NSTØ80)

1) Loosen the hex bolt with wrench on stopper holder and release lock nuts(M6).



VIEW B

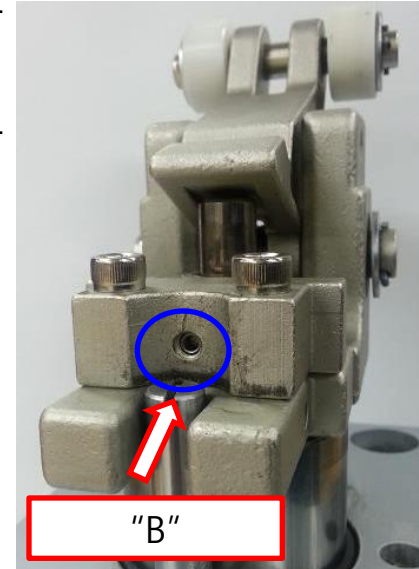

2) Take off STOPPER BLOCK with wrench, lean the lever to 90° and pull shock absorber.

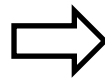

※ Caution
After replacing shock absorber,
please apply grease on rod of
shock absorber.

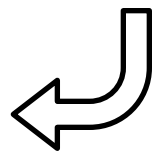
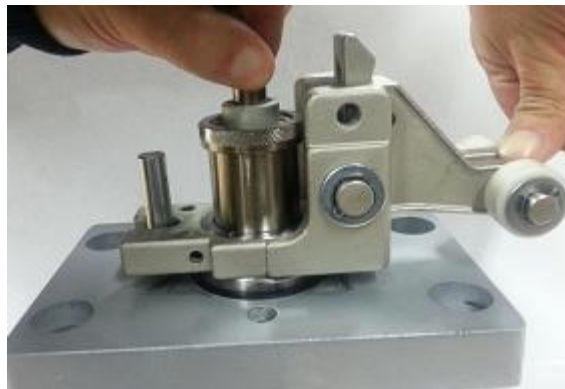



1. Structure

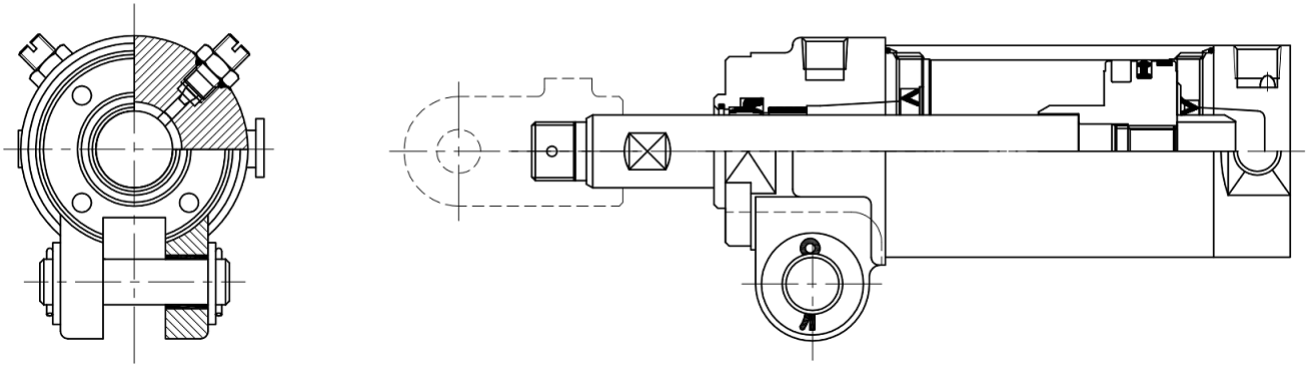

2. Caution

Note : The dis-assembly of AJ and AJM series for maintenance purpose is not allowed.

3. How to adjust cushion valve and speed controller

1) To increase cushion, turn the cushion valve in clockwise direction.

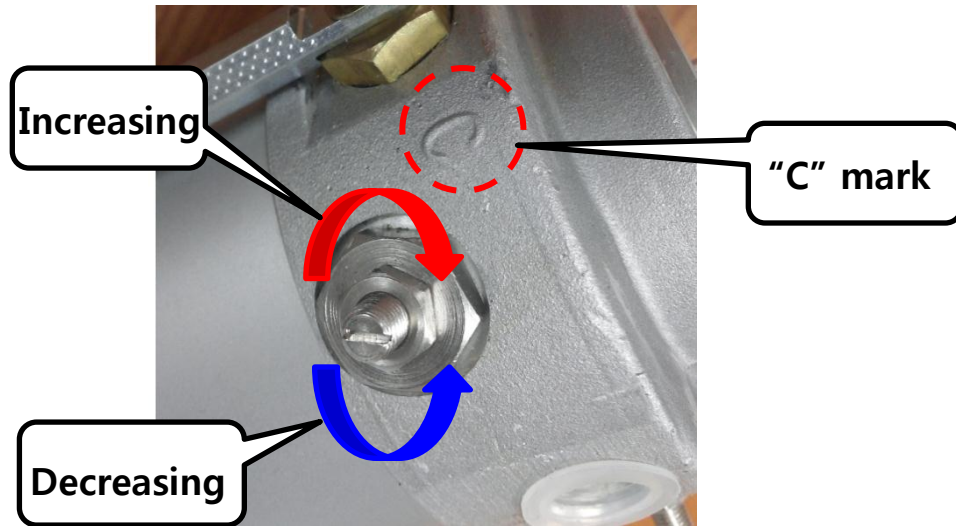

2) To increase working speed, turn the speed controller in clockwise direction.

